



**We shape the industry  
of the future**

# The Inducore mindset





The world is changing rapidly as industries become more specialized and knowledge-driven. As a result, we are evolving into a partner for our customers, who now seek functional solutions rather than just individual components.

We strengthen the global competitiveness of Swedish industry by combining entrepreneurship, internal coordination, best practices, and proactive product and business development.

We deliver world-class products, technical solutions, and services, becoming a "one-stop shop" that leverages our expertise across markets to create greater customer value and drive profitable growth.

A handwritten signature in black ink, appearing to read 'Magnus Biesse'.

**Magnus Biesse**  
CEO Inducore AB

# The Inducore numbers

## Local production, global efficiency

With strategically located production facilities, we ensure efficient manufacturing and strong customer connections. Our focus on regional supply chains reduces environmental impact and increases our agility.

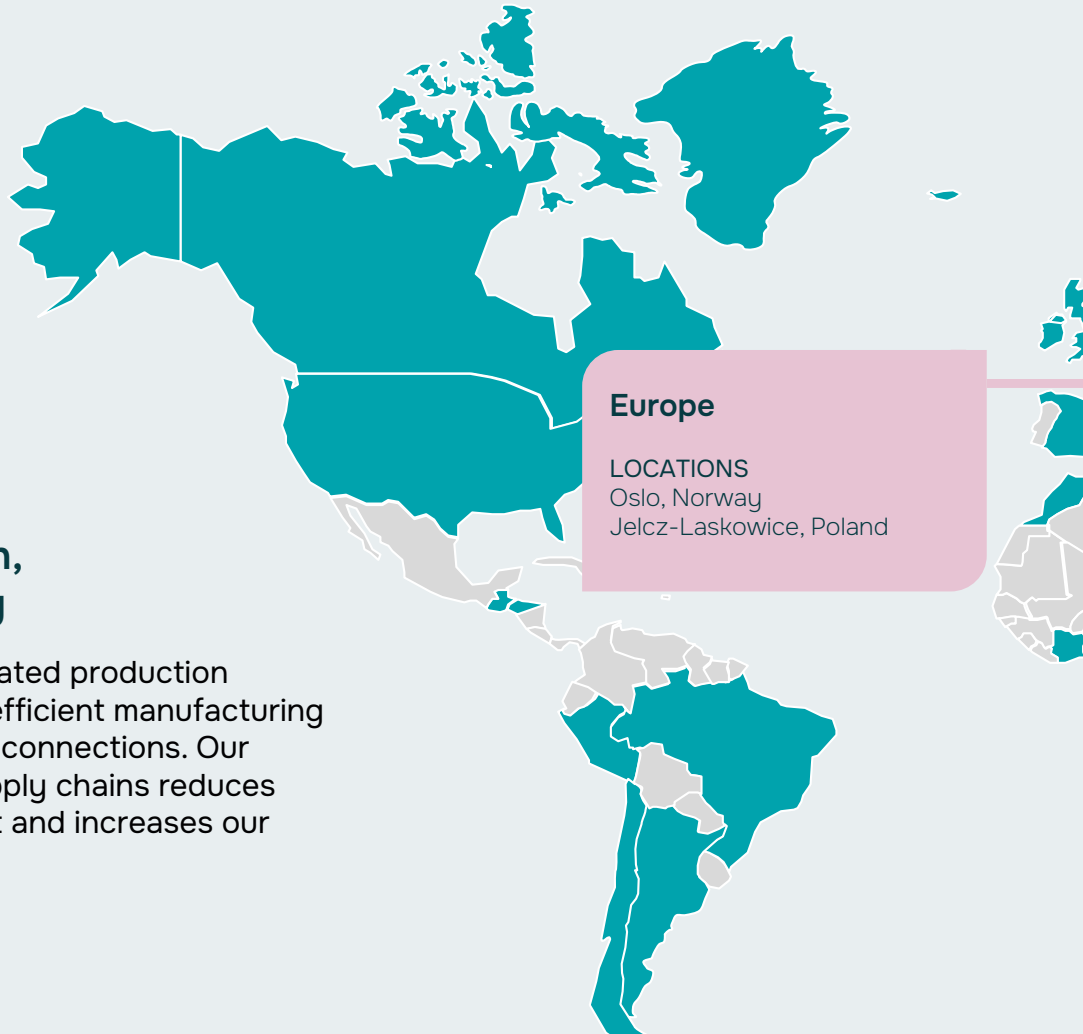

Business areas

3

Production in

4

countries

Production

31

units

Turnover

300

million euros

## Sweden

### LOCATIONS

Bollnäs, Ockelbo, Borlänge,  
Nyhammar, Ludvika,  
Grangärde, Morgårdshammar,  
Hedemora, Uppsala, Västerås,  
Örebro, Nossebro, Eksjö,  
Björköby, Rydaholm, Alvesta,  
Målilla, Mönsterås, Liatorp,  
Sibbhult, Nybro, Kalmar,  
Malmö, Tomelilla,

Design & Development,  
Machining, Surface treatment,  
Welding, Assembly

## Asia

### LOCATIONS

Shanghai, China

Employees

1200+

## Growing markets

As Inducore grows, our vision takes on a bigger global perspective. We are expanding our presence and bringing our values and expertise to international markets. Guided by a clear strategy for sustainable growth, we are shaping the future of industrial solutions, both locally and globally.

# The core



The Inducore Group offers system solutions, products, components, contract manufacturing, and logistics solutions with high quality and reliability.

We strengthen Swedish industry by helping companies grow and develop. With long-term ownership, entrepreneurship, and a focus on sustainability, we provide companies with the tools to reach their full potential.

Together, we create stability that benefits customers, companies, and communities – today and for the future.



# The Inducore people

Inducore values the power of human connection and collaboration, recognizing that our success is built on the expertise, creativity, and dedication of our people.

We believe in fostering a culture where each individual is empowered, respected, and given the opportunity to grow. By prioritizing continuous learning and open communication, we create an environment that sparks innovation and drives sustainable, meaningful progress.

We believe that our dedication to human values is key to consistently delivering exceptional results.





**We invest in people. With strong growth opportunities in our companies and team, we build careers that last.**

**Join us for the long run.**

# Business divisions



## Components

Our Components team acts as a value-creating partner providing innovative manufacturing processes and solutions.

Using our team's technical expertise, we are able to provide services ranging from single components to implementing complete technical solutions.

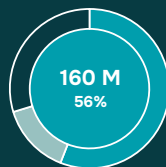

Revenue

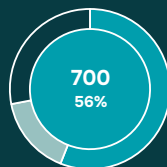

Number of employees



## Truck Bodies

Our Truck Bodies operation is the leading vehicle body builder in the Nordics.

We design, build and supply numerous superstructures for trucks and trailers within construction and contracting, as well as vehicles for distribution and long-distance transport.





## System Solutions

Our Systems Solutions develops and supplies our own innovative products, services and technical solutions.

From the initial concept to the finished product, we work in collaboration with customers across our key niche markets to produce best-in-class solutions.

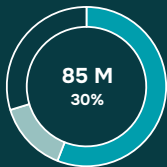

Revenue

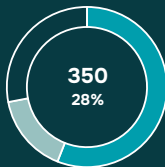

Number of employees

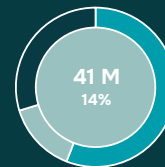

Revenue

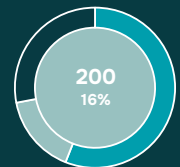

Number of employees

**SÖRLING**



**HIAK**



**Presona**

# Market segment

A strong product portfolio and geographical spread towards strategic markets and customers provide the conditions for sustainable growth and balanced risk, which reduces sensitivity to market fluctuations.

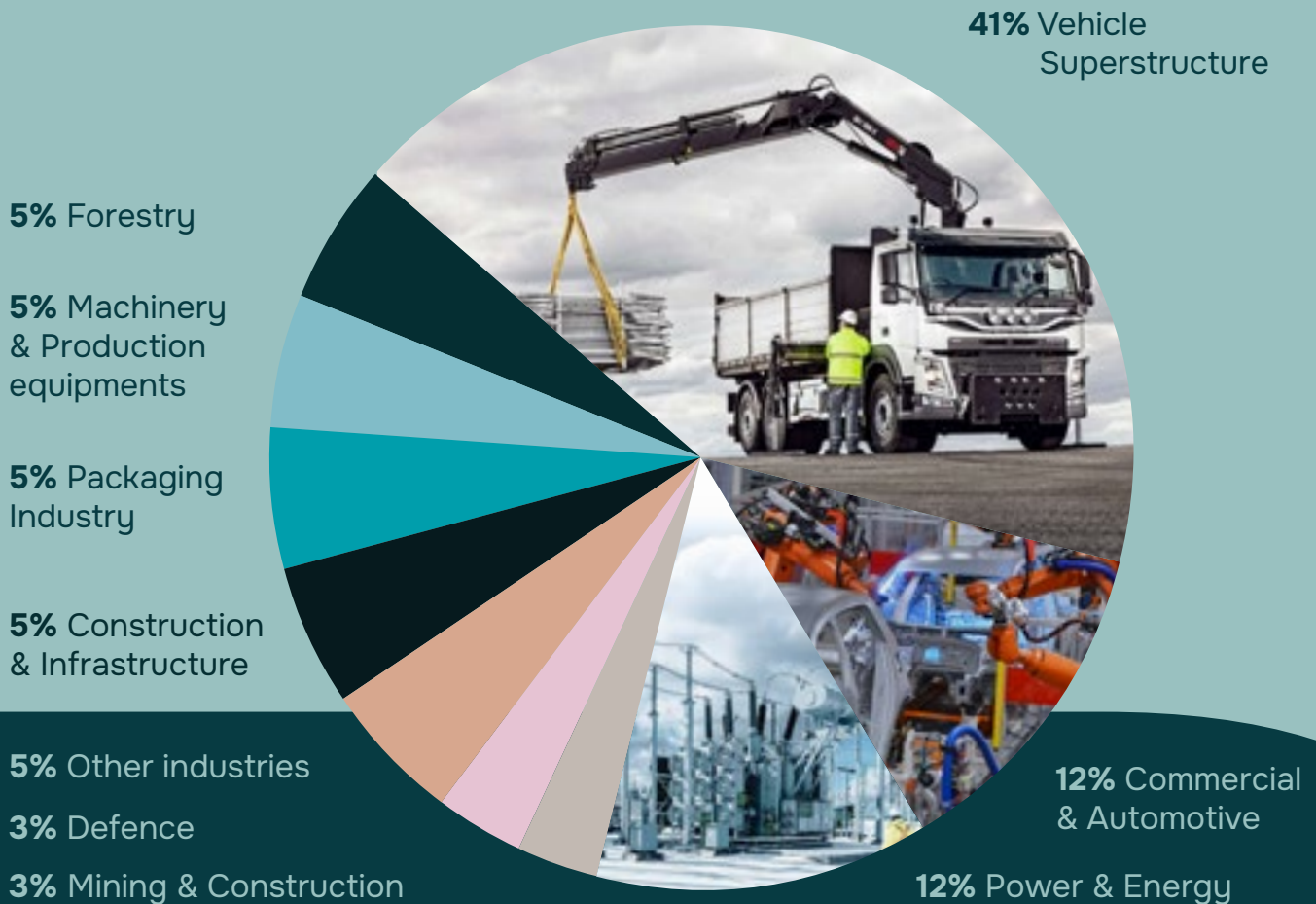

# Customers that trust Components



Commercial & Automotive



Construction & Infrastructure



Power & energy



Forestry & Agriculture



Medical

Machinery & production



Mining & construction



Defence



Construction & Infrastructure



Marine



Other industry

# Sustainability

Aligning business goals with environmental responsibility, ensuring that sustainability remains at the core of everything we do.

Operating in a country aiming for carbon neutrality by 2045, we are at the forefront at sustainability with a focus on renewable energy like wind, solar, and hydropower.

Local production offers environmental and economic benefits by reducing transportation emissions, minimizing waste, and supporting regional economies. It also promotes sustainability through renewable energy, optimized materials, and resilient supply chains, making the process eco-friendly and cost-effective.

We uphold high labor standards, ensuring fair wages, safe conditions, and respect for workers' rights. By promoting social equity and responsible practices, we

support environmental and community sustainability, creating a more just global economy.

CO2-emission, kg/tonne

| Process            | Sweden | Germany | Poland | India |
|--------------------|--------|---------|--------|-------|
| Iron casting       | 29     | 410     | 824    | 1146  |
| Steel casting      | 41     | 577     | 1162   | 1616  |
| Aluminium          | 25     | 354     | 713    | 992   |
| Conventional steel | 1250   | 2000    | 2500   | 2500  |
| SSAB Zero (SE)     | 50     |         |        |       |

Reference: Climate Impact of metal-casting 2023-2024, Swedish Foundry Association



## Inducore Focus areas (UN Sustainable Development Goals)

**Sustainable transport**  
= Reduced climate footprint



**Renewable energy sources**  
= Sustainable energy supply



**Circular economy**  
= Sustainable use of resources



## Sustainability report

From 2021 we set and followed up on clear sustainability goals, culminating in a double materiality assessment aligned with the EU CSRD directive.

Our decentralised structure ensures that subsidiaries drive sustainability, supported by group-wide policies, training, and oversight, with each CEO and board accountable for integration and compliance.

Download and read our full sustainability rapport at [inducore.se/hallbarhetsrapport/](https://inducore.se/hallbarhetsrapport/)

## Advantages of Casting in Sweden

### Low climate impact

Sweden's clean energy supply minimizes emissions from energy-intensive processes like melting.

### Innovation-driven efficiency

Strong focus on digitalization and smart casting methods enhances energy and material efficiency.

### Strict environmental standards

Widespread adoption of ISO 14001 and climate reporting ensures accountability.

### Local market proximity

Shorter transport distances mean lower logistics emissions.

### High recycling rates

Extensive use of recycled metal reduces the need for virgin materials.

### Quality and traceability

High standards reduce scrap rates and unnecessary rework.

**Innovation for the future**  
= Technological shift for a sustainable society



**Safe & secure workplace**  
= Offering an attractive workplace



**Diversity & inclusion**  
= An engaged and motivated workforce



# Complex solutions - One supplier

By offering a fully integrated value chain, we deliver complex solutions through a single point of contact. Our strengths are further enhanced by a close collaboration with our partners.

## Fully integrated value chain

### Development, Design & Engineering

We refine design & ensure manufacturability

#### Partners

Iscar  
Seco  
Prevas

Machine builders  
CAD/CAM

### Raw Material, Casting & Forging

Supply & Sourcing

#### Partners

Componenta  
Draxton  
M. Busch  
Ljunghäll  
Hydro  
Holsbyverken

Norrlands gjuteri  
Ovako  
Vald Birn  
SSAB  
Storebro Gjuteriet  
Profilgruppen

### Machining

From turning to complex 5-axis machining

#### Precise Gears

Precision-engineered gears crafted through advanced, fully controlled manufacturing.

Inducore In-house

Partner Network



Through close collaboration with our sister companies, Anva and PVI, we harness shared expertise, aligned processes, and a unified way of working to deliver added value to our customers.

### **Welding**

Skilled craftsmen to high speed robot welding

### **Surface Treatment**

From pre-treatment to top coat, ED and powder coating.

#### **Partners**

Aalberts surface technologies  
Body coat  
LP Tech AB  
Mastec CCTech AB  
SW Advanced Coating

### **Special Contracting**

Extreme environmental requirements, certifications (ISO, MIL-STD), or to comply with regulations from authorities or the defense sector.

### **Heat Treatment**

Induction hardening,  
Case hardening

Material laboratory for testing, analyzing, and researching the properties.

### **Assembly**

From partial assembly to completion of entire systems.

### **Logistics**

Customized to your needs, we offer warehousing and shipping

**Seamless customer experience** →



# Design & Development

Inducore rethinks the design from the ground up to make it more cost-effective and completely error-proof.

One of our key services that makes us at Inducore a preferred supplier is our industrial production development, optimizing manufacturing processes to deliver high-quality, cost-effective products.

We blend innovative design with practical production considerations, focusing on material selection, manufacturability, and assembly ease. By collaborating with designers, engineers, and manufacturing experts,

we ensure your products are ready for efficient scaling.

Our development process refines design, manufacturing workflows, machinery, and quality control systems, utilizing automation and CAD technology to ensure precision and speed.

## Ensuring manufacturability

From quotation, we analyze designs to spot errors, suggest improvements, and ensure manufacturability, adjusting non-producible elements early for clarity and efficiency. Many reviewed documents have errors.

We find them and suggest options ensuring efficient production as a collaborative partner focused on quality. Problem-solving is our strength - and we leave nothing to chance.

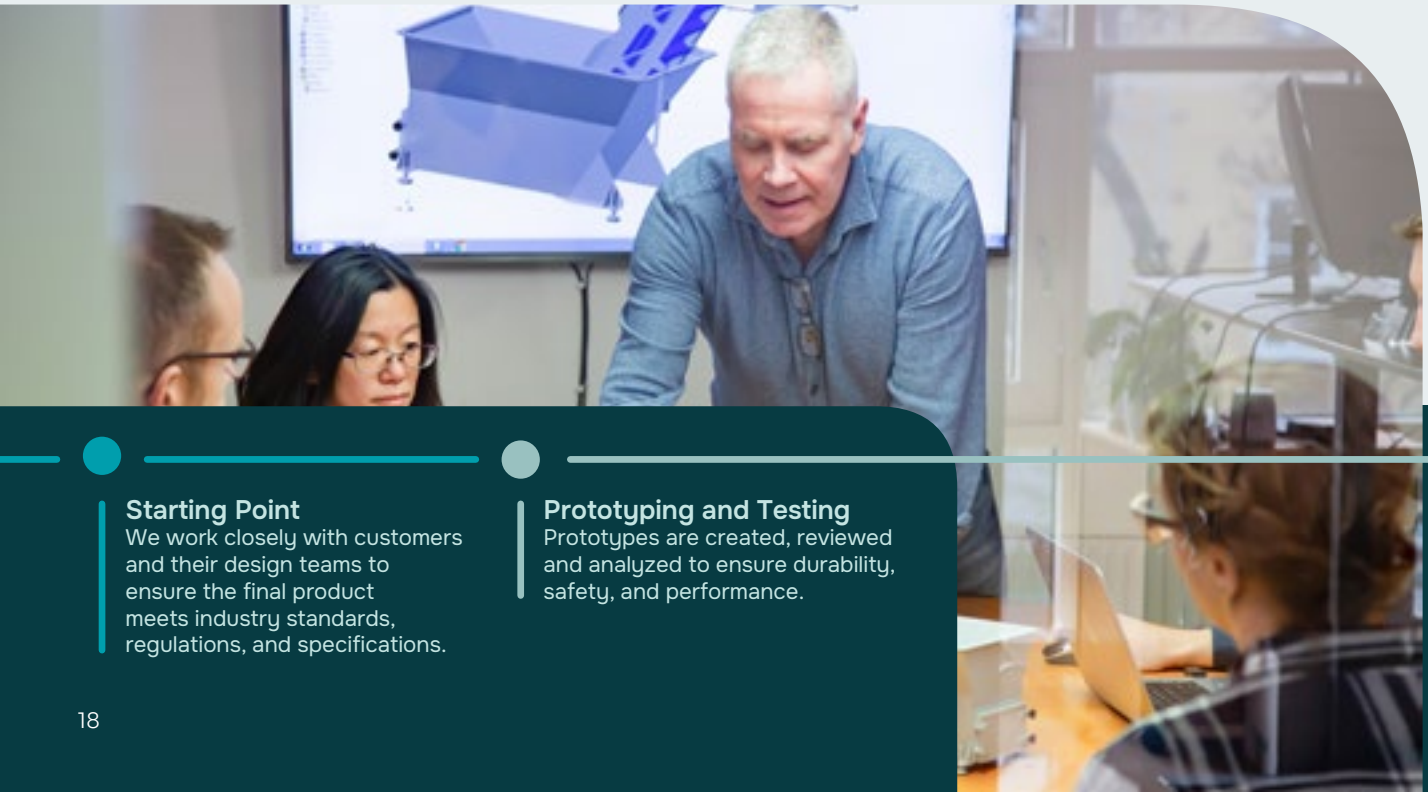
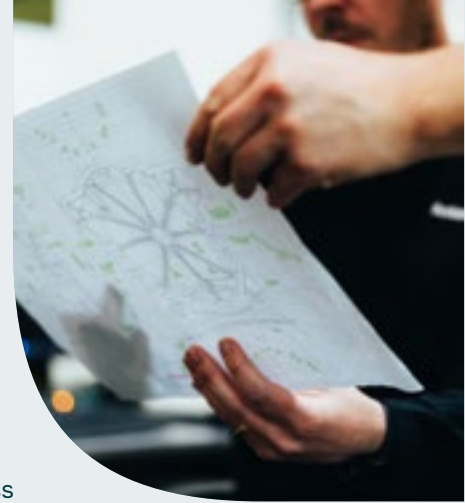

### Starting Point

We work closely with customers and their design teams to ensure the final product meets industry standards, regulations, and specifications.

### Prototyping and Testing

Prototypes are created, reviewed and analyzed to ensure durability, safety, and performance.

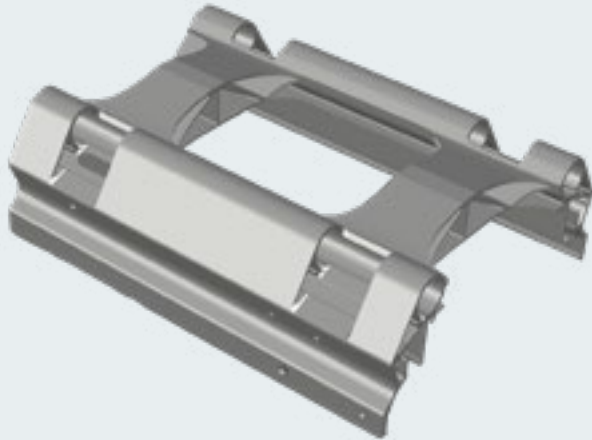

### Thule Easyfold XT

Thule's bike frame, engineered by Inducore together with the customer, faced the challenge of achieving the high precision needed to withstand vibrations and ensure a stable bike attachment.

**Solution** Milling process in separated operations. This ensured the precision required to provide the structure with stability and strength. Machining was split, based on actual component function to meet needed tolerancing between machining and extrusion.

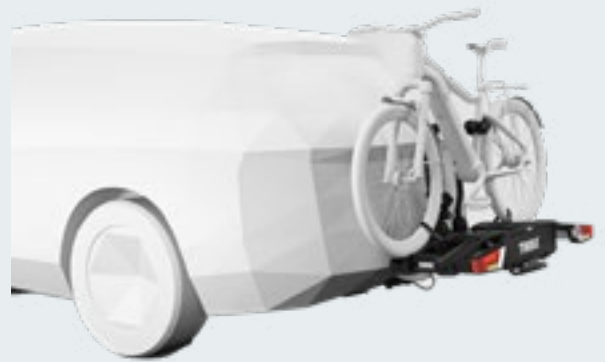

#### Know-How Meets Technology

Our development team combines deep industry expertise and advanced technologies like CAD, 3D printing, and high-performance materials to enhance component strength, durability, and efficiency, ensuring optimal quality and lifespan.

#### Quality Control

Quality is central to our development process, with subcontractors adhering to strict industry regulations and certifications (e.g., ISO, CE) to ensure every component meets required standards.

#### Continuous Innovation

Our in-house team continuously improves product design through feedback and post-launch reviews, staying in close contact with customers to address challenges and keep solutions industry-leading.

# Design & Development

In focus: Transmission



## Transfer gearbox for all wheel drive

Transfer gearbox for all wheel drive trucks, developed and manufactured for demanding heavy duty applications.

Designed to handle high torque levels while delivering excellent efficiency and durability. Featuring five selectable gear ratios and Automatic Traction Control (ATC), the solution offers flexibility, traction, and performance across a wide range of operating conditions.

## Gearbox for precision

A family of high performance gearboxes engineered for applications demanding exceptional precision and reliability.

Designed and manufactured to deliver a zero backlash solution, ensuring accurate positioning, smooth operation, and long term performance.

The gearbox range includes optimized models, covering a wide span of torque requirements and installation needs.



## Process flow

Gear box solutions designed with sustainability in mind, focusing on energy efficiency, lower emissions, optimized material use, and circular manufacturing. Strong engineering and gearbox design capabilities are key to meeting demand for customer-specific gearboxes, high-precision gears, and integrated transmission solutions.

Project starting point based on the customer's specific requirements and performance targets



## Marine diesel applications

An optimized, robust and high-performance drivetrain solution designed for marine diesel outboard applications.

All key components are manufactured and assembled in-house, ensuring high quality, precision, and reliability. The transmission efficiently transfers engine power to the propeller and is engineered to handle high torque and demanding marine operating conditions.

## Gearbox for mineral exploration

A robust gearbox and chuck engineered, developed, and manufactured for demanding deep drilling applications. Designed to support mineral exploration at depths of up to 2.5 km, delivering exceptional reliability and performance in extreme conditions. 800kg.



Design and engineering, including validated calculations and simulations

Prototype development with in-house manufacturing of components and complete assembly

Comprehensive testing covering functional verification and field trials

Efficient and evaluated serial production and assembly.

# Prototyping

The start of error proof full scale manufacturing

| Capabilities | Type      | Inducore handles       |
|--------------|-----------|------------------------|
|              | Machining | 50 gram up to 40 tonne |
|              |           | 5 mm up to 24 meters   |
| Welded       |           | 50m up to 50 tonne     |



## Precision and partnership

We offer prototyping across all processes, helping customers transition smoothly from prototype to medium and high-volume production. We take full responsibility for materials, fixtures, and tools, driving the process efficiently for a seamless experience.

Specializing in complex industrial prototyping, we produce small lots using 3D printing, rapid tooling, and CAM-based machining. Working with strong local

partners, we ensure short lead times and focus on quality, functionality, and efficiency to bring ideas to life faster.

Through close collaboration, we build strong customer relationships and aim to secure long-term volume production, showcasing our expertise, reliability, and commitment to quality at every stage.

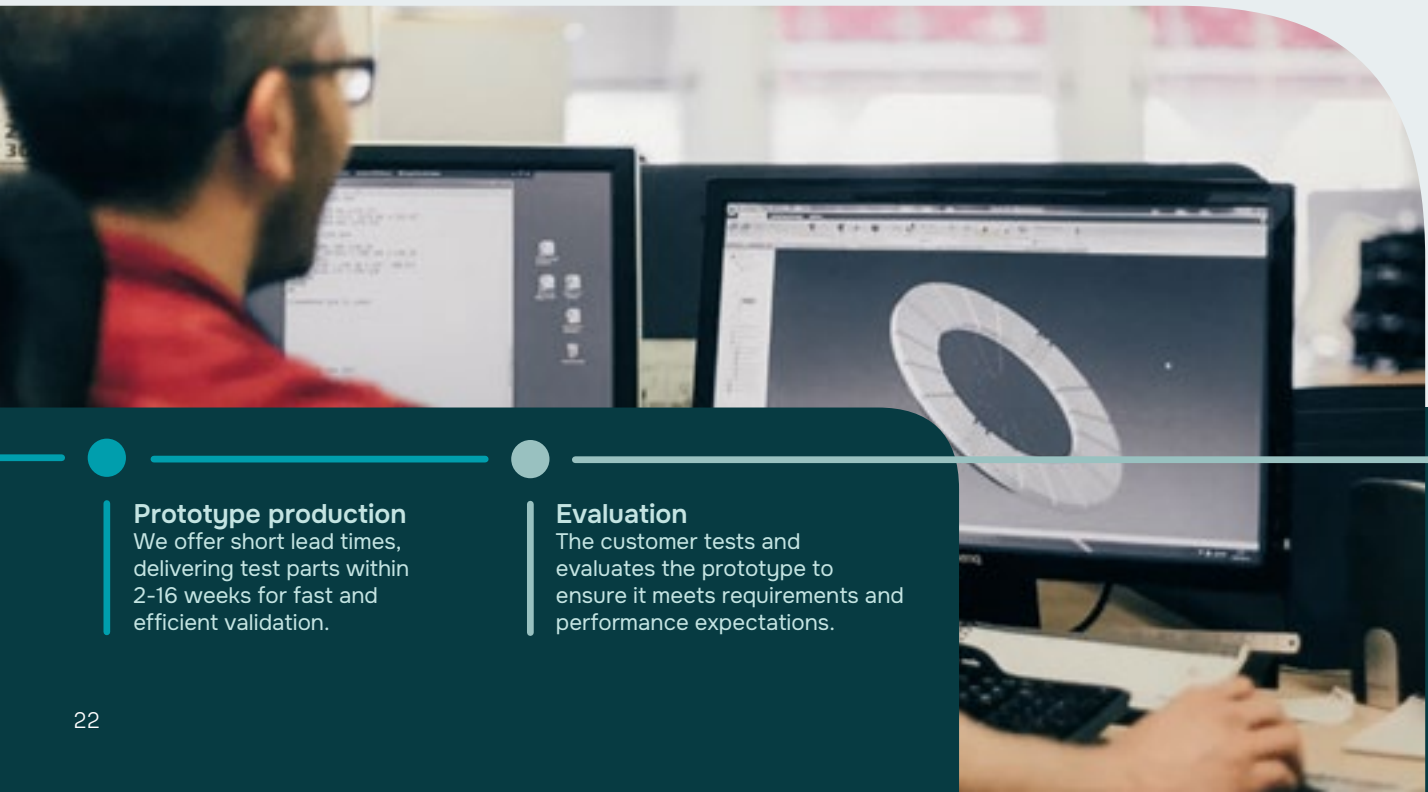

### Prototype production

We offer short lead times, delivering test parts within 2-16 weeks for fast and efficient validation.

### Evaluation

The customer tests and evaluates the prototype to ensure it meets requirements and performance expectations.

## Components manufactured by

### Rapid prototyping with 3D-printed sand mold

A 500 mm prototype was needed on short notice. To save time and avoid the cost of wooden models or welded constructions, we 3D-printed the sand mold directly from the CAD file. By skipping several traditional steps in the process, we were able to deliver quickly – from digital design to machined casting in minimal time. This is a clear example of how additive manufacturing is transforming foundry technology when speed is critical.

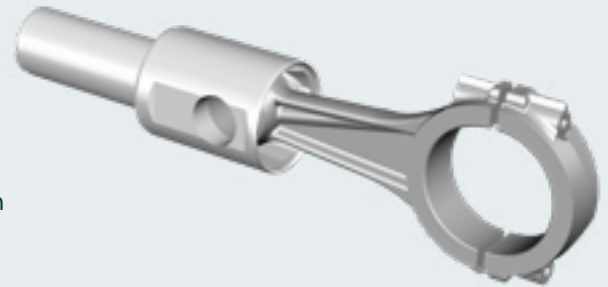

### CNC-milled foam model for casting

A machinery manufacturer required a large prototype base for radiation therapy equipment, measuring 2.5 meters in diameter, with a very tight delivery schedule. To save both time and cost, we replaced traditional welded construction and expensive wooden models with a CNC-milled foam model for full mold casting. The result was a precise, dimensionally stable ductile iron prototype – delivered rapidly and at only 10–25% of the cost of a conventional model. This allowed the customer to proceed quickly with testing and further development.

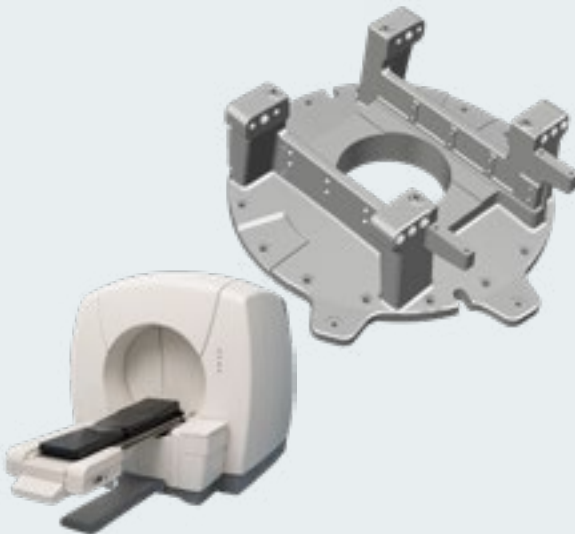

#### Changes / Improvements

After testing and evaluation, necessary changes and improvements are made to optimize the product.

#### Pre-series

A pre-series may be produced for market testing, ensuring the product meets expectations before full-scale production.

#### Full scale production

With our involvement from prototype to production, we accelerate time to market while optimizing costs, materials, and overall efficiency.

# Machining Medium Volume

Component volume 10 - 10 000

| Capabilities |          | ∅     | Lenght | Width | Height | Weight           |
|--------------|----------|-------|--------|-------|--------|------------------|
|              | Milling  | 1 000 | 10 000 | 4 000 | 7 000  | 0,05 - 15 000 kg |
|              | Turning  | 2 500 | 28 000 | NA    | NA     | 0,05 - 15 000 kg |
|              | Grinding | 500   | 4 000  | 2 000 | 1 000  | 0,05 - 10 000 kg |

Measurements in mm



## Precision and efficiency

Inducore specializes in machining for the efficient production of components in moderate quantities, typically ranging from hundreds to thousands of parts, balancing precision with cost-effectiveness. This process is ideal for OEMs and suppliers who demand consistent quality and on-time delivery.

We manufacture in all requested materials, offering flexibility and agility to adapt to our customers' needs.

Our streamlined processes and problem-solving approach ensure efficiency and accuracy from the start.

Customers choose Inducore for our commitment to high-quality standards, advanced machining capabilities, and reliable service, ensuring their production needs are met with precision and efficiency.

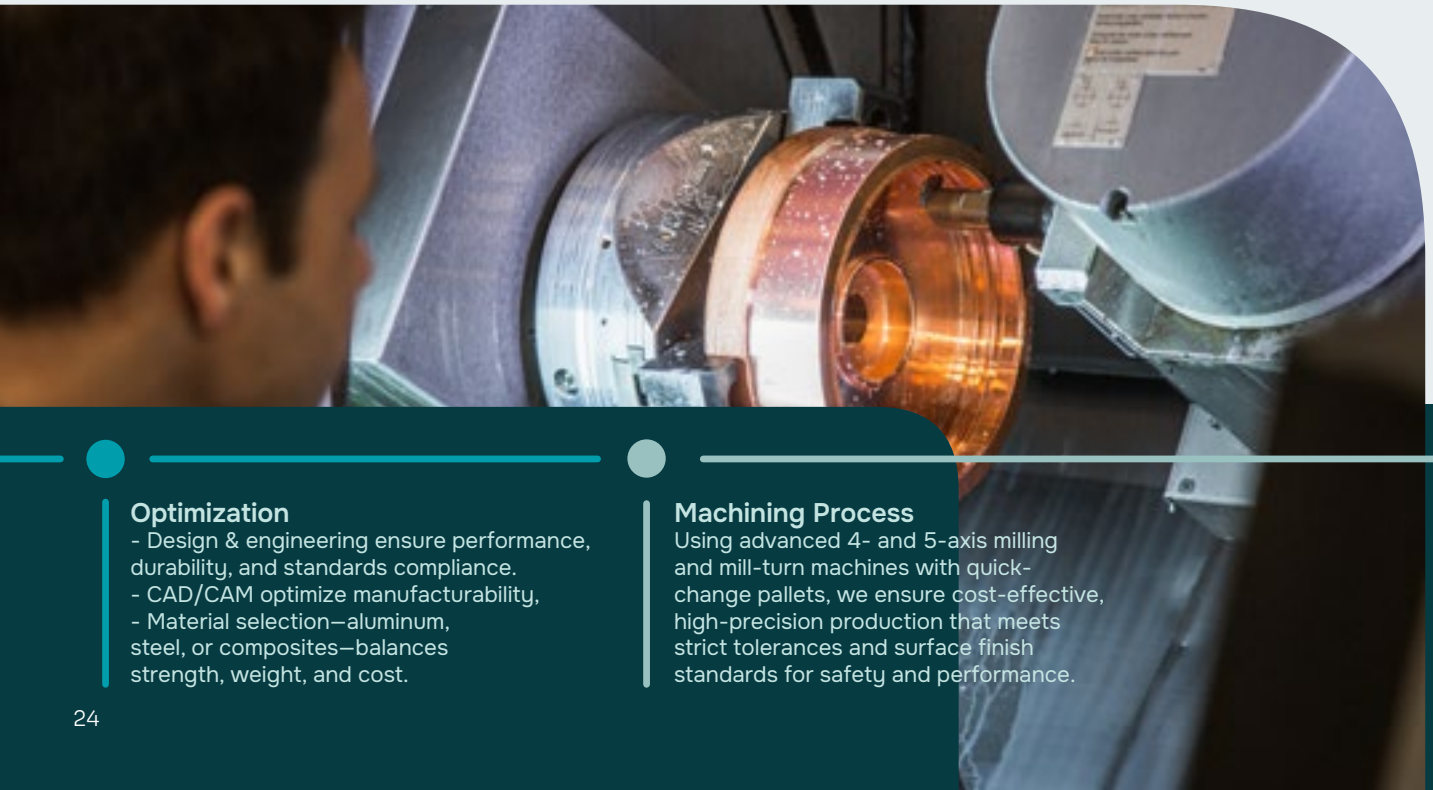

### Optimization

- Design & engineering ensure performance, durability, and standards compliance.
- CAD/CAM optimize manufacturability,
- Material selection—aluminum, steel, or composites—balances strength, weight, and cost.

### Machining Process

Using advanced 4- and 5-axis milling and mill-turn machines with quick-change pallets, we ensure cost-effective, high-precision production that meets strict tolerances and surface finish standards for safety and performance.

# Components manufactured by

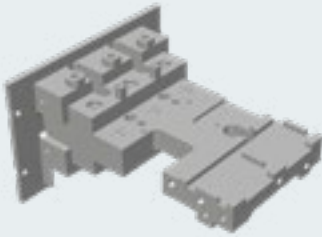

Component **Valve housing** 0,5kg



Component **Brake bracket** 5kg



Component **Pin** 15 kg

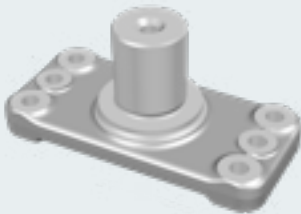

Component **Bracket** 8kg



Component **Rear shaft bridge** 120kg



Component **Brackets** 50kg

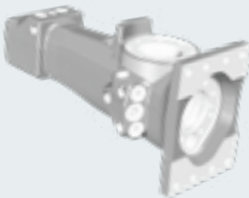

Component **Hammer body** 48kg



Component **Handle** 0,6kg

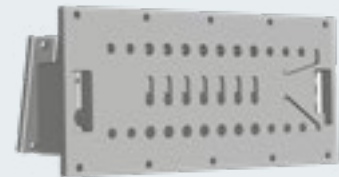

Component **Adapter block** 11kg

## Quality Control

Throughout production, rigorous quality control measures are in place, including automated inspection systems and manual checks. This ensures that each part meets specifications, reducing waste and minimizing the risk of defects.

## Assembly and delivery

After machining, the parts undergo assembly (if needed) and are packaged for delivery to OEMs or Tier 1 suppliers. The ability to scale production within a medium-volume range allows for flexibility in meeting demand while maintaining high quality and competitive pricing.

# Machining High Volume

Component volume 10 000 - 1 000 000

| Capabilities |          | ∅     | Length | Width | Height | Weight          |
|--------------|----------|-------|--------|-------|--------|-----------------|
|              | Milling  | 1 000 | 2 000  | 2 000 | 2 000  | 0,05 - 2 000 kg |
|              | Turning  | 1 000 | 4 000  | NA    | NA     | 0,05 - 2 000 kg |
|              | Grinding | 400   | 2 000  | 2 000 | 1 000  | 0,05 - 2 000 kg |

Measurements in mm



## Precision machining meets sustainable scalability

Inducore's high-volume machining with fully automated production lines ensures precision, efficiency, scalability, and flexibility. We deliver high-quality components quickly and cost-effectively, meeting the industry's demanding needs.

By combining advanced technology with sustainable practices, we provide reliable production while

prioritizing eco-friendly operations across our entire supply chain.

Our adaptable and scalable production lines allow us to adjust output swiftly, maintaining high standards of quality and sustainability. This flexibility enables us to respond to market changes efficiently while upholding our environmental commitments.

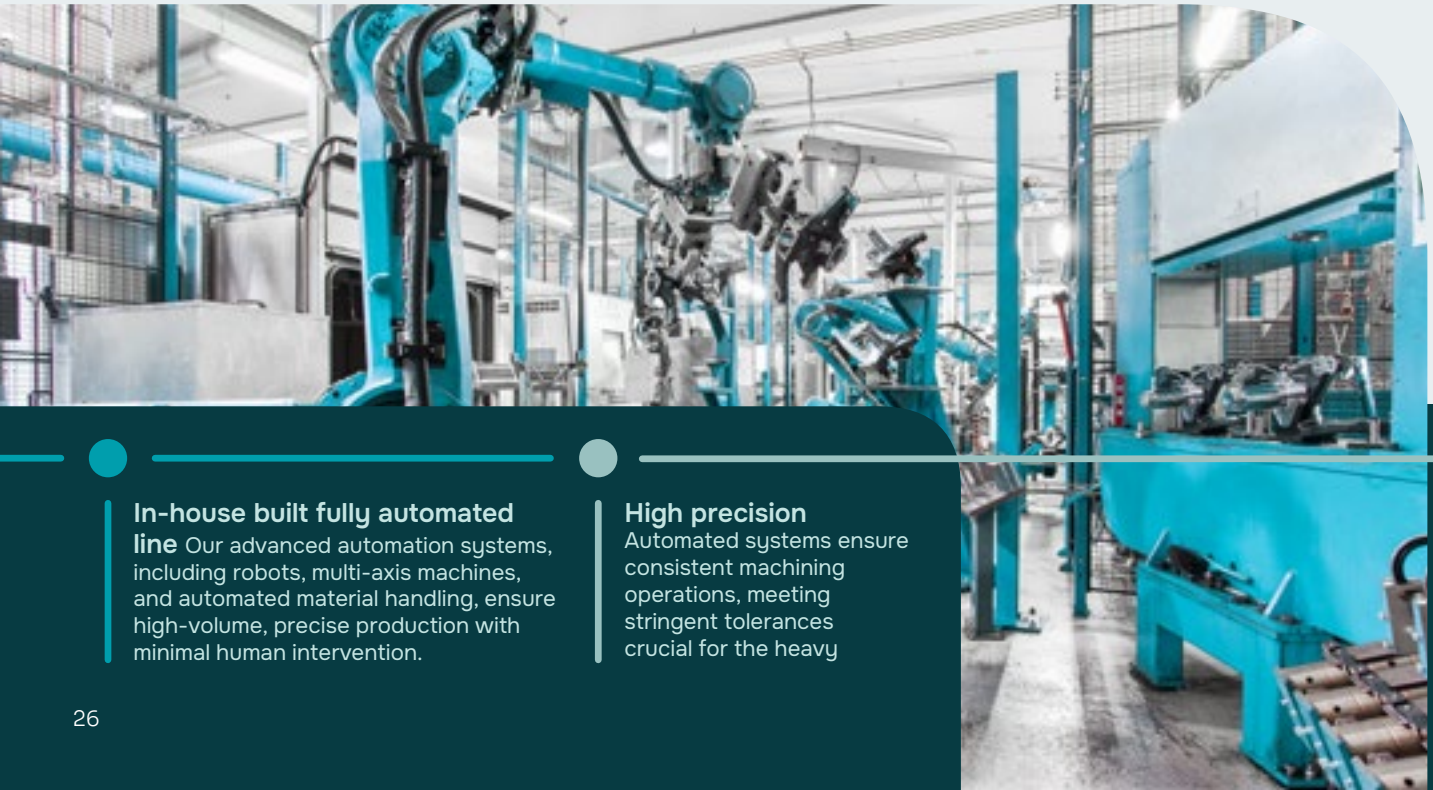

### In-house built fully automated line

Our advanced automation systems, including robots, multi-axis machines, and automated material handling, ensure high-volume, precise production with minimal human intervention.

### High precision

Automated systems ensure consistent machining operations, meeting stringent tolerances crucial for the heavy

## Components manufactured by

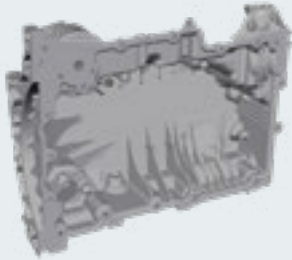

Component **Oil pan** 4,2kg



Component **Crossmember** 80kg



Component **Angle head** 0,7kg

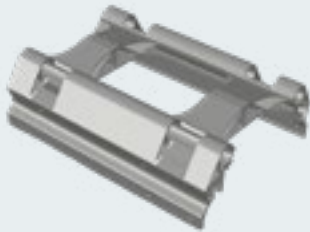

Component **Bike stand** 2 kg



Component **Battery bracket** 38 kg



Component **Sideboard latch** 1,5kg



Component **Steering knuckle** 30kg

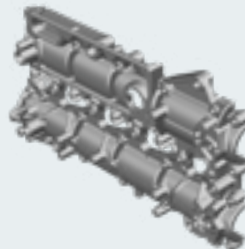

Component **Cam housing** 3,2kg



Component **Timing gear plate** 10 kg

### Efficient material handling

Automated systems optimize production flow, reducing downtime and improving efficiency.

### Quality control

Integrated inspection systems perform real-time quality checks, maintaining high standards throughout production.

### Scalability & cost efficiency

Fully automated lines offer scalable manufacturing, reducing labor costs, minimizing waste, and optimizing energy use.

# Machining Transmission

Component volume 1 - 500 000

| Capabilities | ∅        | Module |
|--------------|----------|--------|
|              | 20-600mm | 1-5    |

Measurements in mm

## Mechanical transfer of force and power

Modern and competitive manufacturers of customer unique gearboxes, precision-grounded or honed gears, and other transmission-parts for vehicles and industry. In cooperation with our customers, we take overall responsibility for design, engineering and manufacturing of transmission components and solutions.

Wherever power and force are shifted up, down or transferred mechanically, we have production, packaging and logistics solutions.

Manufactured components are used in the assembly of complete gearboxes, power take-offs, and related transmission systems.

These assemblies are delivered either to internal gearbox assembly operations or directly to customers for integration into automotive, forestry, and construction machinery. Both in batch and sequence deliveries.



### Turning

The forged blanks are turned to create a geometrically accurate semi finished component, preparing the part for subsequent gear cutting operations.

### Gear / Spline Cutting

The gear teeth are machined depending on gear type (spur, helical, bevel, planetary, etc.) Common methods include:

- Gear hobbing  
the most common method for external gear teeth
- Gear shaping  
suitable for internal external gear teeth

### Broaching

When internal straight splines are required, broaching is used to achieve the specified geometry and accuracy.

### Heat Treatment

Majority of gears are case hardened in in-house case hardening furnaces to achieve the required surface hardness and core strength. An in-house materials laboratory enables controlled analysis and validation of components

## Components manufactured by



Component **Sun Gear** 5,5 kg



Component **Output Shaft** 16,3kg



Component **Gear Crankshaft** 2,8 kg



Component **Engine PTO** 16 kg



Component **Transfer Gearbox** 165 kg



Component **Engine Gear** 8,2 kg



Component **Idler Gear** 3,9 kg



Component **Planet Gears** 1-2 kg



Component **Single PTO** 11 kg

### Gear Finishing

In subsequent operations, the gears are either ground or hard turned. In the final step, gear grinding or gear honing is performed to achieve the required final precision and surface finish.

### Measurement & Quality Control

Comprehensive inspection is performed and includes, among others:

- Gear geometry measurement (profile, pitch, lead)
- Run out and concentricity measurement
- Surface roughness measurement

### Delivery

The finished gears are delivered with appropriate corrosion protection and customer specific packaging solutions, designed to prevent damage during handling and transportation.

# Sheet metal & Welding

Component volume 1 - 1 000

| Capabilities |               | ∅      | Lenght   | Width | Height | Weight           |
|--------------|---------------|--------|----------|-------|--------|------------------|
|              | Welding       | 15 000 | 0-25 000 | 5 000 | 4 500  | 0,05 - 65 000 kg |
|              | Press-brake   |        |          |       |        | 650 ton          |
|              | Sheet cutting | N/A    | 12 000   | 2 500 | 150    | 10 ton           |

Measurements in mm



## Reliable engineering with precise craftsmanship

We blend traditional skills with advanced technology to create sustainable, high-performance solutions. We consistently deliver high quality by combining deep industry knowledge with modern production techniques. Our expertise in small batch manufacturing ensures precision and flexibility tailored to unique customer needs. For higher volume production we always use robot welding for securing quality and right price level.

Our energy-efficient welding methods and environmentally friendly materials help reduce emissions and waste, without compromising on quality.

Focused on building long-term partnerships, we aim to be a trusted partner for all welding and sheet metal projects – delivering value through every detail.



### Material Preparation

Sheet metal is sourced, cut to required dimensions, and cleaned to remove contaminants before welding.

### Design & layout

CAD designs guide cutting, bending, and welding to ensure precise assembly.

### Bending & forming

The sheet metal is bent into shape using press brakes or roll forming machines.

# Components manufactured by

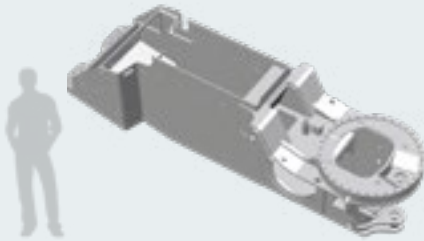

Component **Base frame** 1547 kg

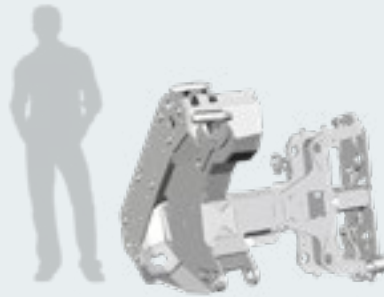

Component **Harvest head** 770 kg

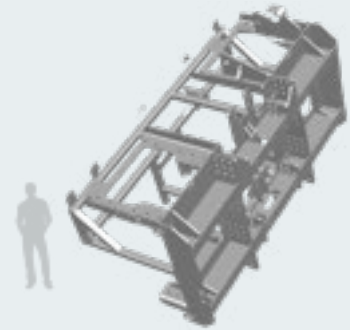

Component **Winch rack** 650 kg



Component **Foot step** 13kg

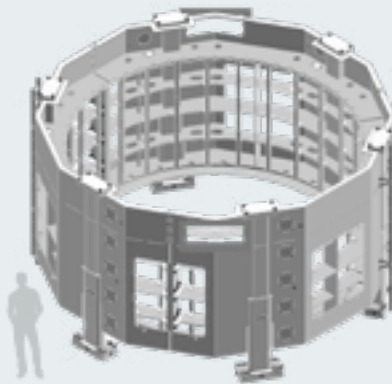

Component **Frame** 30 ton



Component **Claw knife** 80 kg

## Welding

Components are welded together using methods like MIG or TIG welding for a strong structure. WPQR and WPS is used to ensure quality of required component.

## Handling & Quality Control

Components undergo inspections and tests to ensure strength and alignment. ISO-standard 3834-2, 15085-2, 1090-1 is used in the welding process.

## Finishing

On customer demand the component can be grounded, sanded, or polished, and surface treatments like powder coating or galvanizing can be applied for durability and aesthetics.

## Assembly & Packaging

Welded components are assembled into larger systems and carefully packaged for delivery.

# Surface treatment

Component volume 1 - 500 000

| Capabilities |                              | Lenght | Width | Height | Weight   |
|--------------|------------------------------|--------|-------|--------|----------|
|              | Powder coating               | 2 500  | 600   | 800    | 450 kg   |
|              | Conveyor capacity            | 2 500  | 600   | 800    | 450 kg   |
|              | Pre-treatment                | 2 500  | 600   | 800    | 450 kg   |
|              | ED (Electro Dipping coating) | 2 500  | 600   | 800    | 450 kg   |
|              | Wet paint                    | 24 000 | 2 000 | 3 000  | 3 000 kg |

Measurements in mm



## Exceptional result every time, on time.

Inducore is a trusted provider of high-quality, sustainable surface treatments, committed to efficiency and environmental responsibility.

Our advanced processes—including zinc-manganese phosphating, ED coating, wet painting, and powder coating—deliver exceptional results for industries such as automotive and heavy vehicles.

With an automatic closed system, we handle parts up to 450kg, offering tailored solutions for durability and corrosion resistance. Our eco-friendly powder coating and cost-effective options for all batch sizes make us an ideal partner.

We ensure quick turnaround, flexibility, and on-time delivery, providing reliable results every time.



### Pre-treatment

12 step pre-treatment process, featuring zinc-manganese phosphating. This ensures the right conditions for a durable result. We offer pyrolysis and sandblasting when necessary. Parts pass through an automatic closed system, guaranteeing high-quality standards before the application of ED coating, wet painting, or powder coating.

### Primer

After pre-treatment, a primer is applied to enhance the adhesion and durability of the coating. This ensures optimal bonding between the surface and subsequent layers.

# Components manufactured by

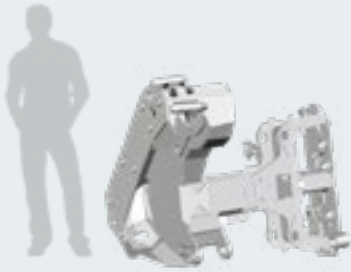

Component **Harvest head** 770 kg



Component **Electrical battery bracket** 38 kg



Component **Grid power flange** 332 kg



Component **Wheel cover** 80 kg



Component **Fork** 180 kg



Component **Crossmember** 80 kg

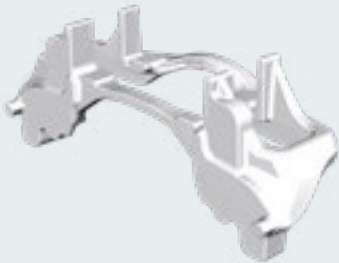

Component **Caliper** 10kg



Component **Isolator** 186 kg



Component **Engine bracket** 20 kg

## ED Coating

ED coating provides full-coverage barrier protection with high corrosion resistance. Combined with zinc-manganese phosphating, it ensures durability. Thickness (18-30  $\mu\text{m}$ ) is adjustable per application.

## Wet painting

Wet painting is applied for additional surface protection or aesthetic requirements. This process is ideal for parts needing a smooth and consistent finish.

## Powder coating

Powder coating is a solvent-free, eco-friendly process. Powder can be applied as a single layer coating or in a two layer system together with ED coating for increased corrosion resistance. With three color-change boxes, our line ensures cost-effective production, even for small batches.

# Assembly

Component volume 1 - 250 000

| Capabilities | Type                | Inducore handles        |
|--------------|---------------------|-------------------------|
|              | Components weight   | 50 gram up to 50 tonnes |
|              | Components size     | 5 mm up to 50 meters    |
|              | Assembly complexity | 2 - 2 000 parts         |



## Simplify the supply chain

By integrating both in-house and externally produced parts into a streamlined assembly process and managing the project efficiently, we deliver high quality, cost-effective products.

Inducore simplifies the supply chain, leading to smoother production, fewer bottlenecks, and reliable on-time delivery—crucial in today's competitive market.

Our flexible approach allows scalability to meet varying production volumes, while our strict quality control ensures that all components, whether sourced internally or externally, meet the highest standards.

This integration enhances efficiency, reduces costs, and ensures customer satisfaction throughout the production cycle.



### Project management

A project manager coordinates production, manages timelines, and resolves any supply chain issues. Risks are mitigated with contingency plans.

### In-house production

Parts are designed, manufactured, and quality-checked in-house before being prepared for assembly.



# Components manufactured by



Component **Fan bracket** 7,5 kg



Component **Boggie bracket** 395 kg

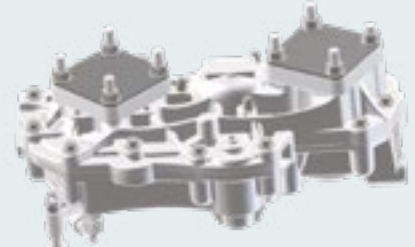

Component **Dubbel PTO** 25 kg

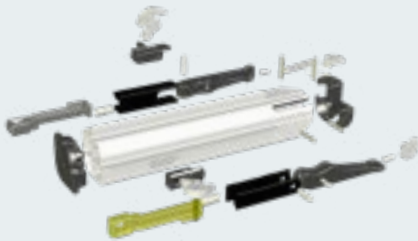

Component **Sideboard latch** 1,5kg

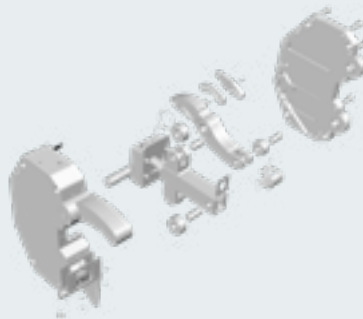

Component **Steady rest** 73 kg

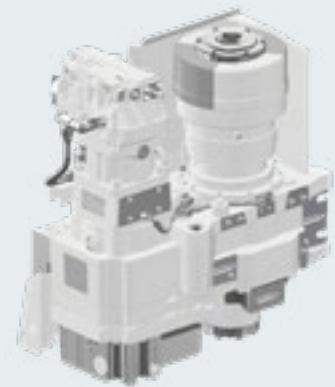

Component **Gear box** 800 kg

## External supplier coordination

Suppliers are selected based on quality, lead time, and cost. Parts are ordered, inspected upon arrival, and discrepancies are addressed.

## Assembly process

Parts are assembled with precision, and tested to meet performance and safety standards.

## Final inspection & delivery

The assembled product undergoes quality & functional inspection before packaging and timely delivery as per customer specifications.

# Commercial Vehicles



## High level of automation

Our production is highly automated with advanced robot-tended machines. With full automation from incoming to outgoing pallets. Operators monitor robot cells rather than handling products directly. This way we keep man-cost below 5% of the part piece even though we operate in a high salary region.

We focus on long-term solutions, cost-effective processes, and maintaining open communication with customers.

Our core expertise lies in chassis, power train and engine components. To ensure optimal manufacturability, we begin supporting our customers right from the prototype phase. Early involvement of production experts is crucial to developing components optimized for efficient production.

“We keep choosing Axipto thanks to their entrepreneurial spirit and ability to make necessary actions and investments for increasing quality and productivity. Axipto also takes a large responsibility for the supply chain by actively managing the tier 2 partners enabling improved delivery performance and quality. An important base for our co-operation is an open and clear communication.”

TOBIAS OLSSON  
Sourcing Manager, Scania

## A collaboration through trust and high productivity

Axipto is dedicated to being customer-focused, ensuring smooth supply chains and timely deliveries through proactive communication. Our expertise in automation gives us a competitive edge, designing and building all production lines in-house.

We are enhancing our already robust supplier base through deeper collaboration within Inducore Components. By leveraging the collective strength of the entire group, we aim to continue improving and growing.

Scania has been a customer of ours since the early 1980s. This strong partnership has allowed us to improve productivity, stable developing processes, and meet Scania’s demands for continuous price reductions.

Looking ahead, our focus is on further developing our highly automated production and raising the quality bar even further.

State of the art trucks built from state of the art components. ➤



SCANIA

# Automotive

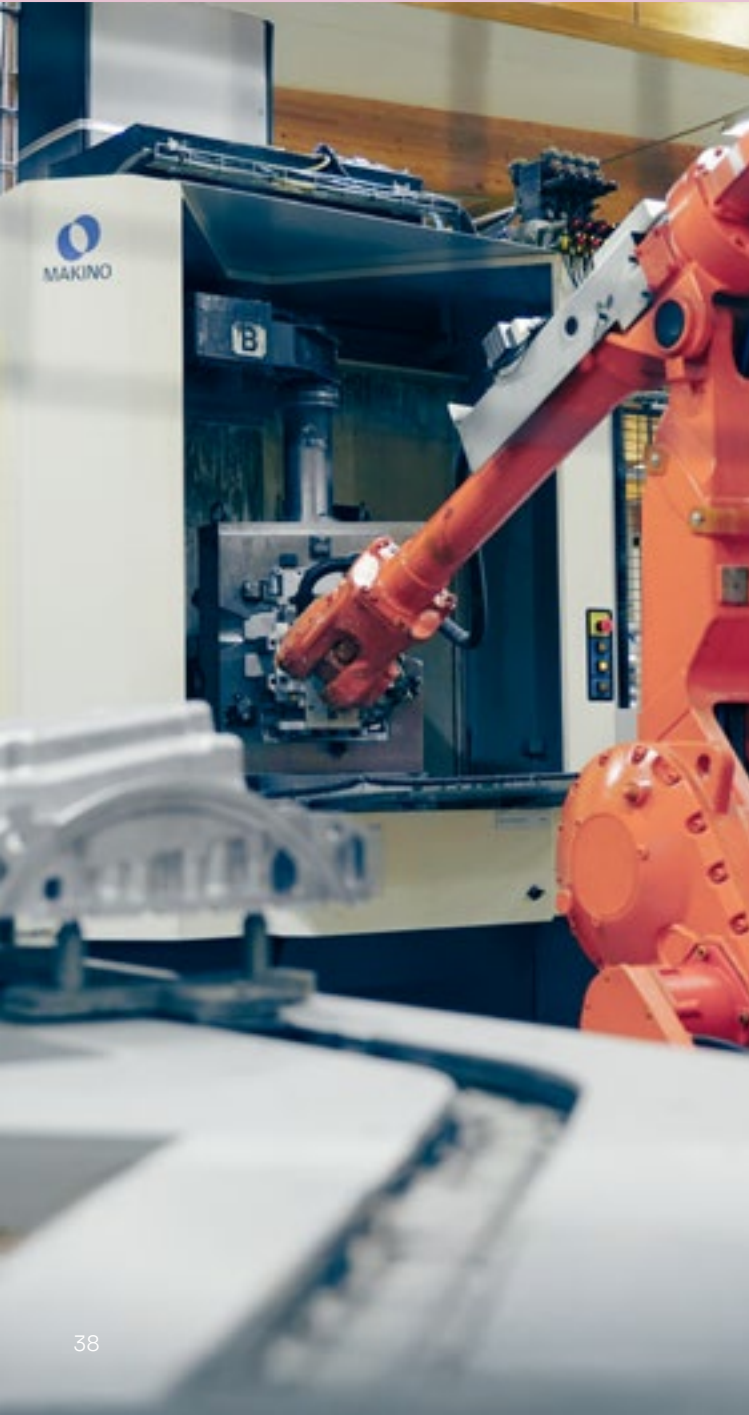

## Optimized production

We offer a wide range of parts for light vehicles, based on precision machined high pressure die cast and extruded aluminium components for low weight and cost efficiency. By engaging early in development, support the customers designing for optimal production methods to efficiently reach production volumes up to 1,000,000 parts annually.

We are delivering defect-free production, meeting deadlines, and building long-term relationships while ensuring mutual success through continuous improvement.

## Case: Oil sump Ljunghäll

“Within the Gnutti Group, of which Ljunghäll is a part, we place high expectations on our suppliers, especially regarding quality, logistics, total cost, innovation, and commitment. Over the years, BMA has demonstrated strong performance in several of these areas, as well as a clear willingness to grow and improve. Our long-standing partnership reflects the continued trust BMA has earned as one of our strategic suppliers, working with us to ensure added value for our customers and owners.”

CATRIN LOMAN  
Purchasing Manager, Ljunghäll

## A long-standing partnership as strategic supplier

BMA has maintained a close collaboration with Ljunghäll since the mid-1990s, focusing on high-volume production of complex, die-cast components – primarily for the automotive industry, where strict requirements are placed on quality, delivery precision, and competitive pricing.

One example is the dual-sourcing arrangement with Volvo Cars, where Ljunghäll and BMA share the production volume delivered directly to the engine plant in Skövde, ensuring an efficient and secure supply chain.

Looking ahead, our focus is on further strengthening quality assurance at every stage to minimize disruptions for our customers.

Volvo XC60 



# Defence



## High quality products on time

We always aim to exceed customer expectations. While it's easy to say, truly delivering on this promise is far more challenging, but it's a promise that drives everything we do.

Utilizing the skills of our employees blended with the latest in machine and automation technology. We deliver on the customers demands for short lead times on highly complex parts in volumes from 1 to 1000 pieces per year.

The defence industry is at the forefront of technological advancements and demands the highest standards from its suppliers. Tolerances, precise documentation, and on-time delivery of high-quality products are essential. Building long-lasting, strong relationships with customers in this sector will provide mutual benefits for years to come.



ÅSA AXELSSON  
Director Global Sourcing  
SAAB

”With the entire product lifecycle in mind, the supplier has showed a pro-active mindset in combination with world class skills to support all relevant disciplines within SAAB such as product development, sourcing and supply. During 2018 they have showed commitment to the business and independent of request they have delivered high quality products in time, enabling SAAB to successfully deliver their commitments to the end market”

## Preferred supplier

As a preferred supplier to Saab, we know that our close collaboration across all stages– from prototypes and pre-series deliveries to serial contracts - is the key to building long term mutual trust.

Having partnered with Saab for over 30 years, we are confident that our relationship will continue to thrive for many years to come. We are incredibly proud of the trust Saab has shown in us, especially when we were honored with the ”Supplier of the Year” award in 2018 for one of their business areas.

SAAB gripen model E the pinnacle of Swedish engineering.



**SAAB**

# Material & foresthandling



## Delivering durable, robust solutions

We take full responsibility for manufacturing complete sheet metal structures in medium to large sizes. From blank cutting to final assembly, we deliver comprehensive solutions using advanced technology and top-level expertise.

With over 25 years as a trusted supplier in forestry and construction, we bring solid know-how and a wide range of skills. We are a key part of the value chain for larger welded components, offering plasma and laser-level cutting, bending, robot welding, machining, assembly, and painting—even for parts weighing several tons.

Short lead times enable us to deliver everything from prototypes to serial production. Our dedicated teams collaborate closely with customers to continuously develop innovative, high-quality processes.

”We prioritize suppliers with whom we want to build long-term partnerships. Inducore is one such supplier.”

DANIEL MELIN  
Purchasing/Logistics  
Plantma Forestry

## A Complete and Reliable Partner in Production

For us at Plantma, Inducore is a crucial partner that takes a comprehensive approach to production – from sheet metal processing to welding.

overall costs. Inducore is not just a supplier – they are a long-term partner who actively contributes to our development and success.

With their broad technical expertise, they are able to deliver complete solutions under one roof, which simplifies the process and increases efficiency.

Inducore not only offers a wide range of services – they do so at a highly competitive cost level. By introducing robotic welding into our production, they have also improved the quality of our products while reducing



Plantma >

# Machine & production tools



## Cost-effective complex production

For years, we have focused on developing specialized processing methods and fixtures for machining extremely thin-walled workpieces. We handle everything from prototypes cut from solid material to high-volume production using cast materials, all produced with exceptional precision and narrow tolerances.

Our strength to serve customers in mechanical engineering lies in balancing high-volume, low-assortment with low-volume, high-assortment production, always prioritizing quality and customer satisfaction.

We serve various industries, offering logistics solutions, complex machining, and give feedback on product adaptations to improve machinability, reduce costs, and enhance quality.

Using modern 4- and 5-axis milling machines with quick-change pallet systems and multifunction mill-turn machines, we ensure cost-effective production without compromising on quality.



”This enables us to source roughly 95% of all parts directly from within the group”

PETER LINDBERG  
CEO  
Atling Steady Rest

## From Components to Complete Solutions

Each Atling steady rest is built from around 80 unique components. As an independent company, we leverage the full strength of the Inducore Group’s comprehensive supplier portfolio. This enables us to source roughly 95% of all parts directly from within the group.

Having all suppliers under the same umbrella offers a decisive advantage: exceptional flexibility.

The companies within Inducore can seamlessly support one another,

ensuring reliable supply, faster response times, and a smoother production process from start to finish.

Self-centered steady rest



STEADY REST

# Mining & construction



## Rapid production changes

In the low to medium volume segment of mining and construction equipment we have been a trusted supplier since 1948, with highly efficient processes and the shortest setup times, our flexibility, commitment to quality and open-minded approach have built this long standing relationship.

With machining as well as coordinate measuring machine capabilities reaching from a few to over 3000 millimeters - we are fulfilling our customers needs for a range from small to very large components. Utilizing 5-axis machining centers even for the largest work pieces, we finish the parts in few setups making production very cost effective. In our workshops we produce parts in almost any material requested, from aluminium to ductile iron and cast or forged steel.

”In this project we had a very close collaboration with Axipto and thanks to that it has been possible to get a short project time and a very quick start-up time for all the products.”

TORSTEN KÄMPFER  
Global category manager  
Epiroc

## Speed, trust and collaboration in manufacturing

The Axipto philosophy is centered around the belief that having dedicated people within our organization, combined with close collaboration with our customers, leads to significant gains for both parties.

For many years, we have partnered with Epiroc on both small and large projects, acting as a ”one-stop-shop” for outsourcing substantial volumes of machining.

We practice open-book transparency, fostering strong reliability and trust between us and our customers. Our close relationship with Epiroc essentially makes us an extension of their own factory. Axipto and Epiroc share a long history together, built not just on geographic proximity, but also on a deep, collaborative partnership.

Team from Epiroc and Axipto. Behind one of the largest one piece hydraulic hammer bodies.



# Energy



## Powering progress. Precision products.

We produce high-quality, reliable components for the energy sector – supporting everything from traditional power generation to renewable energy solutions. Our products are designed to perform in demanding conditions, where safety, efficiency, and longevity are critical.

Whether serving wind, hydro, solar, or conventional energy applications, we deliver tailored solutions that meet rigorous technical standards and sustainability goals. Our manufacturing processes are rooted in precision engineering, strict quality control, and a deep understanding of the evolving energy landscape.

Through innovation and long-term collaboration, we contribute to a more resilient and sustainable energy infrastructure – helping our customers meet the world's growing power needs with confidence and responsibility.



LARS BERGMAN  
Head of Purchasing and  
Supply Manager, VOITH

”A local flexible and reliable partner with high level of competence in manufacturing of welded fabrications and machining of forgings”

## A stable, reliable partner for long-term cooperation

Sjölanders has had Voith as a customer for nearly 15 years, where the main product has been stator frames and components for stator frames. Voith's high standards for documentation and project follow-up have contributed to enhancing our capabilities in both execution and technical documentation, ending with a FAT test as the final step.

Strong group working in many markets and different segments. Meaning a stable reliable partner for long term cooperation.

Sjölanders made an effort accelerating the delivery of a

Stator frame faster than committed PO date with an already tight schedule to help us reach an important milestone in the project.

Voith hydropower 



**VOITH**

# Medical



## Tight tolerances. Complex standards.

Medical parts are made from a wide range of materials, including steel, plastic, aluminum, brass, and other specialized materials. These components require strict quality documentation and the highest finish. From individual components to medium-sized series of up to 5,000 parts per year, our flexible manufacturing structure supports customer needs.

Medical components demand precision, tight tolerances and complex specifications are standard. Our strength lies in close collaboration and long-term partnerships.

We ensure quality through a comprehensive range of inspection equipment from highly precise hand-held gauges to advanced coordinate measuring machines providing measurement data and certificates as needed. Every part is thoroughly inspected by our operators before delivery. Thanks to our high-precision CNC machines, deviations are rare, but detecting even the smallest ones is essential. Our skilled staff remains our greatest asset in upholding the highest standards of quality.



Contact



## Emanuel Svensson

Business Area Manager Components

Contact

+46 (0)70-567 41 23

[emanuel.svensson@inducore.se](mailto:emanuel.svensson@inducore.se)

## Inducore AB

Kopparbergsvägen 10

722 13 Västerås

Sweden

Where companies and  
people grow together.

Sustainable, profitable  
and with pride in  
every step.