

# LogMessage

## A NEW DATA LOGGER

Stand alone. Secure. Fast.

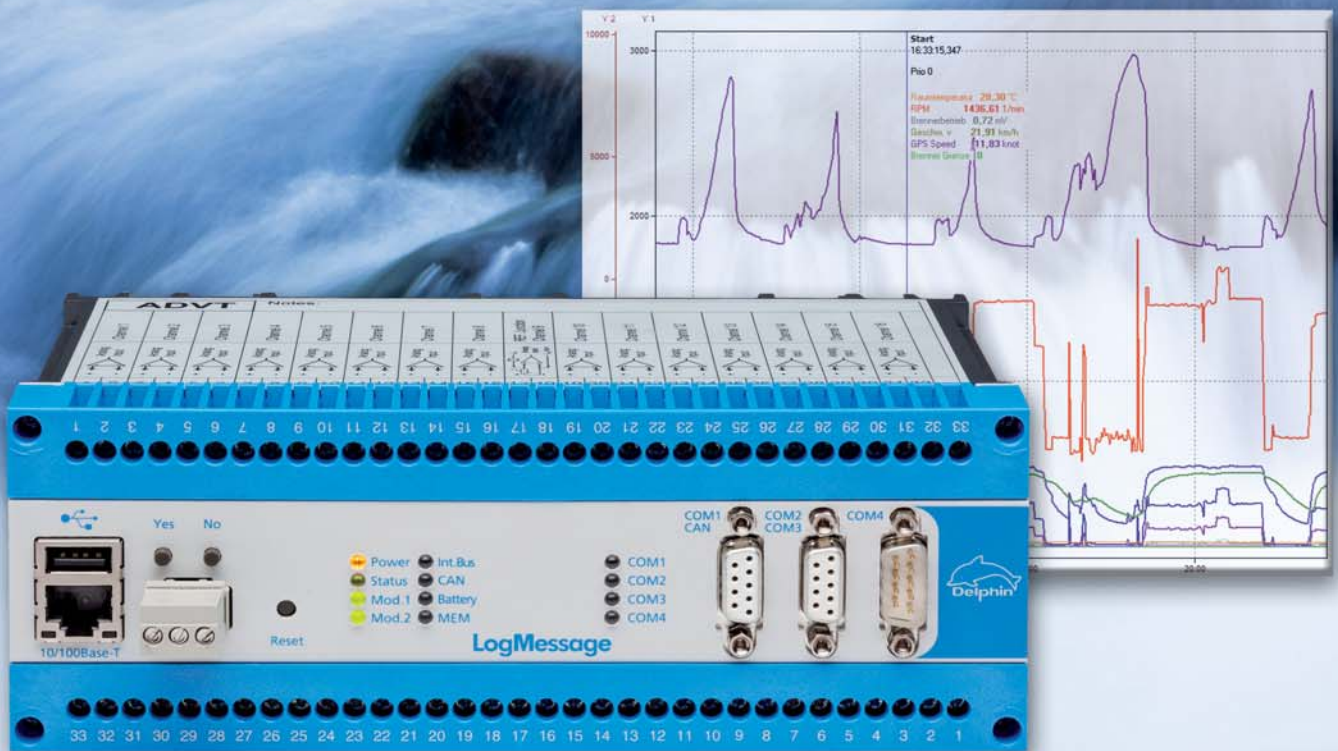

# LogMessage – A data logger for professional

## Extensive functions

LogMessage data loggers are universal. Whatever the application – for slow or for high-speed acquisition – Delphin has a LogMessage version for any user requirements. Delivery includes the ProfiSignal Go software to enable professional evaluation of online and offline data. LogMessage devices function intuitively making it easy to configure inputs, to save data, and to display data as trends.

LogMessage devices are designed for permanent operation and can be depended on to perform reliably over the long term. When data security and reliability are top priorities, users choose the "Made in Germany" logger.

## A range of interfaces

- LAN interface
  - Device configuration and online data transfer to PC
  - Link to UMTS-routers
  - Log memory read-out
  - Modbus TCP for data transfer using PLC
- USB interface
  - Log memory read out
- Serial interfaces
  - 4 x RS232/485
  - Customer-specific protocols (ASCII)

## Universal sensor connection

LogMessage devices are precision instruments that can be switched via software to function with any type of sensor.

- Universal use of analog inputs for mA-, mV-signals, RTDs, or any thermocouple
- Signal rate of 0.1 Hz to 10 kHz
- Digital inputs suitable for up to 90 VDC
- Frequency inputs up to 35 kHz

## Galvanic isolation included

LogMessage devices are fully protected against earth loops enabling measurements from non-isolated sources.

- All analog inputs can function as differential inputs
- Isolation voltage between analog inputs: 110 VDC to a maximum of 650 VDC
- Galvanic isolation between power supply and each interface
- No earth loop problems

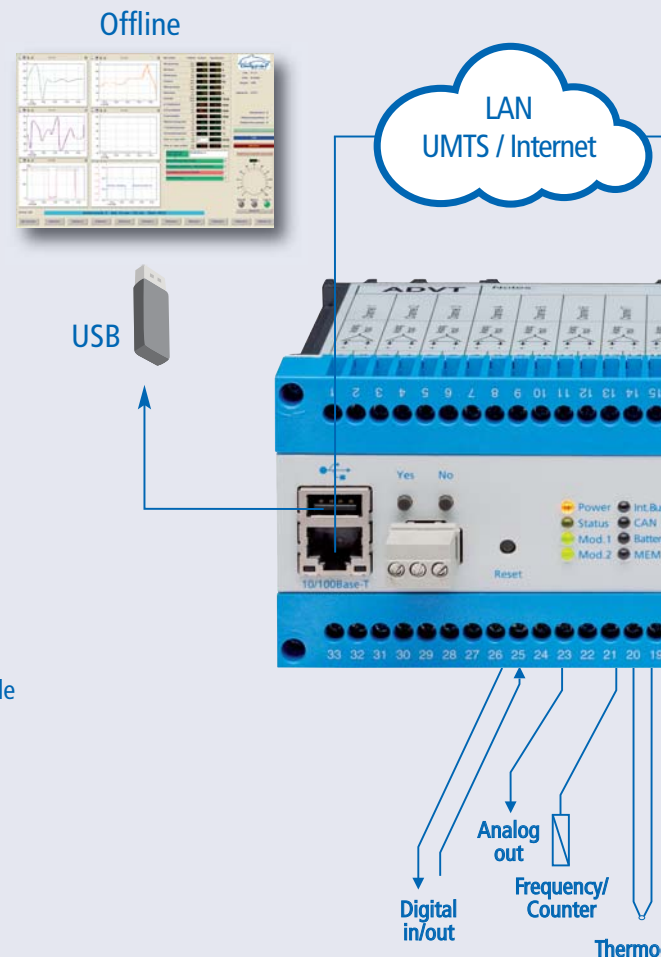

# ssionals

## Applications

- Secure data acquisition with stand alone capability
- PC-independent measurement and testing
- Acquisition via universal inputs
- Product testing, laboratory, R&D
- Mobile data acquisition
- Fault diagnostics at machine/plant
- Status and event logging
- Energy efficiency measurements
- GPS data logging and remote monitoring
- Temperature data acquisition

Online

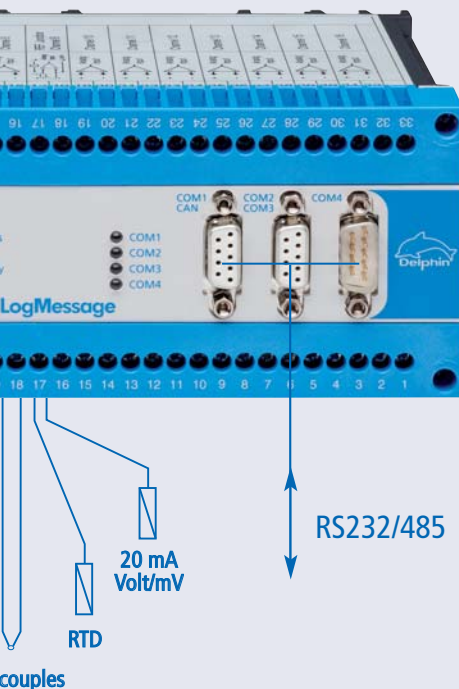
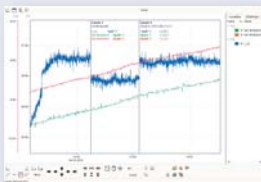

## Secure data storage

The LogMessage's data storage capability enables it to function without PC or network support.

- 3.5 GB of memory for 250 million data records
- Each measurement data record is recorded with a time-stamp (date and time – at microsecond precision)
- Measurement data can be assigned to groups and used as triggers
- No data loss in the event of power failure
- Alarm management with pre and post alarm data

## Comprehensive signal processing

Software channels, configurable according to requirements, can be used for online calculation, monitoring, and many other functions. This enables data to be generated that is immediately usable.

- Online calculations performed on measurement data (e.g. temperature differentials)
- Integration functions (e.g. flows to volumes)
- Limit value monitoring with alarm functions (switching digital outputs)
- Counter function and operational data acquisition

## Resolutions for demanding requirements

LogMessage devices are suitable for both slow- and high-speed measurements. Time resolution for analog measurement data is at 100- $\mu$ s precision levels; digital resolution at millisecond precision. The devices are equipped for precision measurement with 24-Bit ADCs.

# Versions

| Typ  | LM 1000 | LM 2000 | LM 3000 | LM 4000 | LM 5000 | LM 6000 | LM 7000 | LM 8000 | LM 9000 |
|--|---------|---------|---------|---------|---------|---------|---------|---------|---------|
| Analog input (mV, mA, thermocouple)        | 15      |         | 15      | 8       |         | 15      | 30      | 15      |         |
| Analog inputs (mV, mA, thermocouples, RTD) |         | 10      |         |         | 16      | 10      |         |         | 20      |
| Analog output (mV, mA)                     |         | 1       |         | 2       |         | 1       |         |         | 2       |
| Digital inputs (frequency measurement)     |         | 12 (11) | 24      | 28 (2)  |         |         |         | 12 (11) |         |
| Digital outputs (mV)                       |         | 17      | 1       | 5       |         | 1       |         | 16      | 2       |
| Sampling rate in measurements per sec.     | 600     | 600     | 600     | 10000   | 80      | 1200    | 1200    | 600     | 1200    |
| Isolation voltage DC (AI to AI)            | 110     | 110     | 110     | 100     | 650     | 110     | 110     | 110     | 110     |

LogMessage is available in nine different versions. LogMessage is a genuine high-speed logger with sampling rates of up to 10,000 measurements per second.

The LM 5000 version has an increased isolation voltage of up to 650 VDC between inputs.

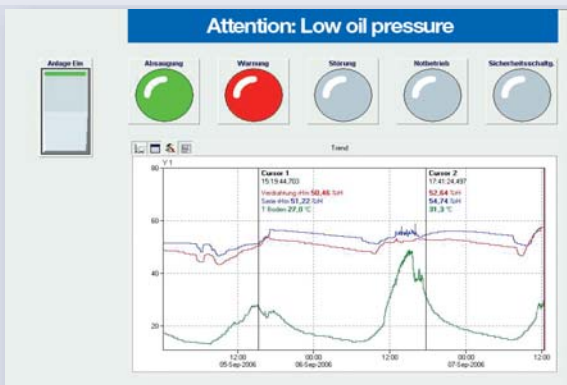

## Web server included

LogMessage devices are equipped with internal web servers. The standard version displays current measurement data in a channel list as well as extensive configuration and maintenance information. In combination with the ProfiSignal WEB option, views can be generated and loaded into the LogMessage in HTML5.

## Software channels

Software channels are capable of performing computations on online measurement data, and used for visualisation, storage or monitoring purposes. The processing of signals takes place independently within the LogMessage device and requires no PC support. There is virtually no limit on the number of software channels that can be used. Software channel computations run parallel to data acquisition and logging. Software channels are included in delivery.

| Online analysis         | Description   |
|-------------------------|---|
| Calculation channel     | Any number of channels can undergo computation procedures. Functions include: basic arithmetic functions; trigonometry; binary and boolean operations |
| Channel averaging       | Computation of moving and triggered averages  |
| Edge counter            | Counter for impulses (high, low, and reset functions)   |
| Differentiator          | Computes changes over time  |
| Integrator              | Numerical integration over time   |
| Linearization           | Corrective calculations on non-linear sensors   |
| Operating hours counter | Accumulates the time (in hours) of a digital signal's high-level  |
| Statistic channel       | Computes moving and triggered statistical values (min, max, variant, standard deviation)  |
| Stopwatch               | Time measurement between two events   |
| Monitoring              | Description   |
| Limit value             | Generates events for threshold violations (over- / under-runs, inertia, hysteresis, process monitoring)   |
| Batch alarms            | Generates a single alarm from multiple input channels   |
| Wake function           | Generates pulses at a chronological point in time (once a day, week, month...)  |
| Status monitoring       | Evaluates status information for measurement data and generates an alarm  |

# ProfiSignal Go – included

## Quick to deploy

LogMessages are delivered with the professional PC-software ProfiSignal Go, used for online/offline monitoring and measurement data analysis. Just three steps are required to display measurement data as trends, to analyse the data, and to evaluate offline data.

ProfiSignal Go has a choice of diagrams that can be run simultaneously. The integrated DataService software provides data storage and archiving functions. In combination

with ProfiSignal Go, the DataService also provides many alarm management and monitoring functions.

The DataService enables ProfiSignal to function efficiently and powerfully as well as to process large data volumes via multiple and diverse interfaces.

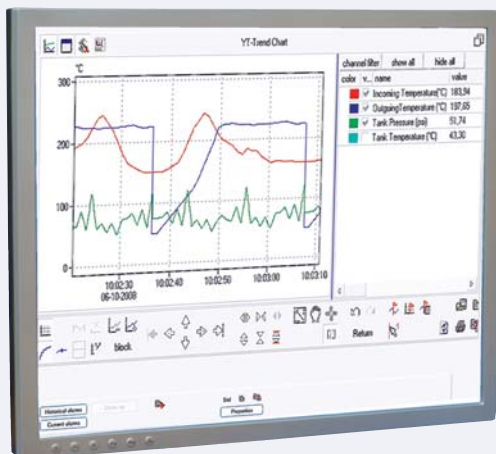

ProfiSignal Go Trend

## Product features

- Monitoring and analysis of any type of measurement data
- Saving experiments to individual files
- Online portrayal in trends
- Uninterrupted switching to offline data
- ASCII-export as CSV-file
- Printout or export as EMF file
- Offline computation functions
- Statistical valuation
- Analysis with cursor functions up to  $\mu\text{sec}$
- Saving of diagram configuration data
- Evaluation of digital signal operation

## Included in delivery

LogMessage devices are delivered with a comprehensive package of software.

- ProfiSignal Go
- LabVIEW™ and DASyLab™ drivers
- OPC-Server
- Modbus TCP
- OCX driver to enable self-programming

## LogMessage





# LogMessage – Technical specifications

| LogMessage                            |  |
|---------------------------------------|--|
| <b>Analog inputs</b>                  |  |
| Voltage/current measurement ranges    | ± 156 mV ... ± 10 V / 0/4 ... 20 mA  |
| Sensors                               | Thermocouples of any type; integrated temperature compensation; resistance thermometer RTD, NTC and linear resistances to 10 kΩ  |
| Potential isolation                   | 750 VDC to the system and power supply;<br>650 VDC between channels for LogMessage 5000;<br>100 VDC between channels for LogMessage 4000;<br>110 VDC between channels for other versions                           |
| Resolution                            | 24-Bit precision V, mA 0.01 % from accumulated value;<br>14-Bit measurement precision: V, mA 0.1 % from accumulated value for LogMessage 4000; Pt100 0.1 K; Pt1000 0.1 K; thermocouple 0.1% from accumulated value |
| <b>Analog outputs</b>                 |  |
| Resolution / potential isolation      | 16-Bit / 750 V; 12-Bit for LogMessage 4000   |
| Output signal                         | 0/4 ... 20 mA at a maximal max. load 650 Ω;<br>0 ... 10 V min. 2.5 kΩ for LogMessage 4000  |
| <b>Digital inputs</b>                 |  |
| Potential isolation                   | 2,5 kV   |
| Input measurement range               | low: 0 ... 1.5 VDC@0 ... 1.5 mA / high: 3.5 ... 90 VDC@2 mA  |
| <b>Frequency / counter inputs</b>     |  |
| Potential isolation / measuring range | 2.5 kV / low: 0 ... 1.5 VDC@0 ... 1.5 mA / high: 3.5 ... 90 VDC@2 mA   |
| Measurement frequency                 | up to 30 kHz at TTL-level  |
| <b>Digital outputs</b>                |  |
| Potential isolation                   | 2,5 kV   |
| Switching voltage                     | max. 50 VDC@2.5 A  |
| <b>Data storage</b>                   |  |
| Standard size / measurement data      | Partitionable storage, standard: 3.5 GB; max. 250 million measurement records  |
| Max. size / measurement data          | 15.5 GB; up to 1 billion measurement records;<br>15.5 GB; up to 7 billion measurement records for LogMessage 4000  |
| <b>Interfaces</b>                     |  |
| Mechanical design COM 1 / COM 2       | RS485, 9-pole Sub-D-connector, DIN EN ISO 19245-1  |
| Mechanical design COM 3 / COM 4       | RS232, 9-pole Sub-D-plug   |
| Protocols COM 1 ... COM 4             | Modbus RTU Master / Slave, customer-specific protocols   |
| Ethernet                              | RJ45 (8-pole STP-connector), 100 BaseT protocol:<br>TCP/IP, HTTP, SMTP, NTP, Modbus TCP Client / Server  |
| USB                                   | USB 1.1 for memory read out  |
| CAN                                   | 9-pole Sub-D-connector, protocols: CAN Raw; baud rates: 50 k ... 1 MBaud   |
| <b>General technical information</b>  |  |
| Dimensions                            | 200 x 73 x 118 mm  |
| Weight                                | 1 kg   |
| Rail mounting                         | DIN EN 50023 or screw fixings  |
| Signal connections                    | Detachable screw terminals, 33 terminals in 2 rows, lead protection,<br>connecting cabling max. 2.5 mm <sup>2</sup>  |
| Temperature range                     | -20 ... 60 °C  |
| Power supply                          | 12 ... 36 VDC / 12 ... 28 VAC eff. / ± 10%;<br>LogMessage 4000: 18 VAC/DC power input: < 10 Watt   |

Delphin Technology AG  
Lustheide 81  
51427 Bergisch Gladbach · Germany

Phone +49 (0)2204 97685-0  
Fax +49 (0)2204 97685-85  
info@delphin.de · www.delphin.com

