



Material flow solutions and assembly lines for the automotive industry

Increase efficiency through smart
conveyor solutions from OCS Overhead Conveyor System



ABOUT

OCS Overhead Conveyor System

OCS Overhead Conveyor Systems offers internal transport systems and unique conveyor solutions for the automotive industry. With our extensive experience from material flow solutions for the industry we can help you solve **Your** internal transport needs.

The foundation for OCS's success is control of our own production in Sweden, but above all our friction-based patented technology for hanging conveyors. A technology that enables us to offer modern industry solutions that are clean and oil-free, ergonomic and quiet, and highly flexible for fast changes.

With more than 500 installed systems globally in a range of different industries, our long experience has given us a strong position as lean production specialists. We create the optimal solutions based on your needs and our know-how.

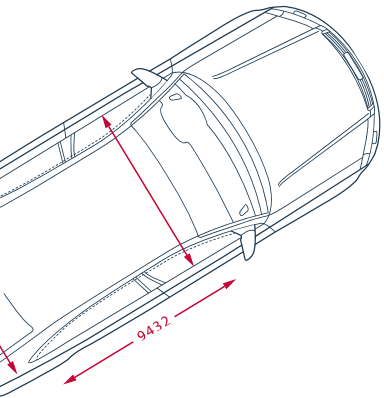

Facts

Owner: Axel Johnson International*, Christer Lundgren, Kenth Almqvist and Mathias Frunz

Headquarters and production: Borås, Sweden

Sales offices: Sweden, Germany, UK, Czech Republic, USA and Japan.

Markets: 30 countries

Installed systems: Approx. 500

Employees: 50 (120 worldwide)

Revenue: 10 MEUR (24 MEUR worldwide sales)

Certifications: ISO 9001 Quality, ISO 14 001 Environment and EN 1090-1

*Axel Johnson International is a global industrial group of more than 150 companies in 30 countries. Axel Johnson International drives business development and growth through a long-term approach to ownership in strategically selected niche markets, primarily technical components and solutions for industrial processes.

More than **500** installed systems globally



Reduce production costs, maximize valuable floorspace and improve work environment

The automotive industry is characterized by complex production with many components that are frequently renewed and modified. Production flows that are constantly challenged and adjusted for handling new models. Like other modern industries, the conveyor solutions must be flexible, effective, clean and quiet. With the OCS friction-based conveyor systems, all requirements for a cost-effective production are achieved.

Our conveyor technology provides:

Overhead conveyor

- Modular & Friction driven
- Quiet, oil free and clean
- Power and free
- Keeps the floor free and accessible
- Variable speed
- Reversible

The carrier

- Customized and optimized
- From small/light to large/heavy products
- For single or multiple products
- Ergonomic workstations
- For buffer, kitting and assembly

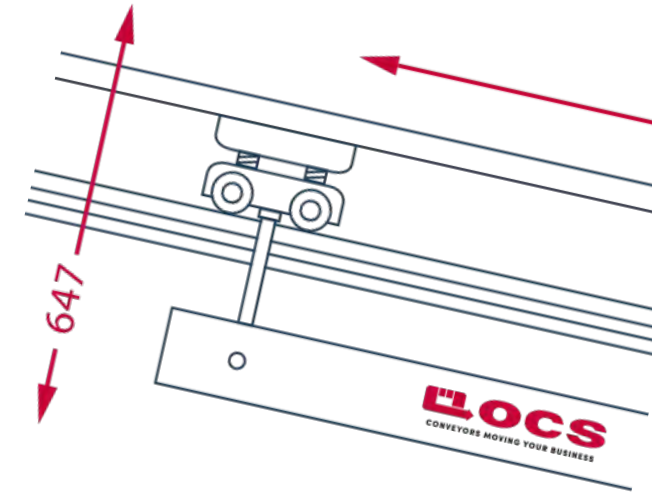

Future proof technology for a complex industry

With an industry in constant change automotive suppliers need conveyor systems that can easily be adjusted to new requirements and shifts in productions. OCS modular and highly flexible system can easily be modified, making it highly suitable for automotive applications.

**Worldwide know how and extensive experience
from the automotive industry!**



Buffering of bumper

OCS 150 bumper buffering system. After assembly, the bumper is sent through an elevator to the mezzanine to buffer. The ceiling height is maximized with this solution. The bumpers are sorted out through three sorting runners to the correct sequence and then released via a lift to relieve racks. The product carrier is designed to handle a variety of variants.



Assembly of the convertible

Two OCS 500 systems for assembly of the convertible. One system transports the three key parts on individual wagons through a mounting process. In the second system, the three parts are placed on a common assembly jig and assembled into a complete unit. Before unloading, the entire cabriolet unit goes through a quality control.



Order picking & assembly of radiators

OCS 500 order picking/kitting details to build a complete radiator. The operator manually transports the trolley or alternatively drives it through the picking area. After loading the trolley with components, it is automatically transported to the available assembly station.



Assembly of Front-End modules

OCS 500 assembly line for Front-End modules (front of the car containing beam, radiators, lamps and bumper). Fully automatic rotation of assembly fixtures in the product carrier to provide the best ergonomic position during assembly. At nominated assembly positions, the OCS carriage can stop with a +/- 3mm accuracy to allow docking of special assembly equipment.



Production line for car tires

OCS 500 system with multiple assembly stations where the operator loads tires onto the OCS product carrier for further transportation to an automatic unloading station. Each assembly station has a 10-minute production buffer. The entire OCS system is ceiling mounted and thus integral with assembly machines leaving clear road access for forklift trucks.



Order picking of parts for door panels

Two OCS 500 systems (front and rear doors) for order picking of in-depth details for door panels. The product carriers are designed to handle all the in-depth details for 9 complete door panels. Picking is guided by the "Pick to Light System" and the entire system communicates with the overall FMS system.

Leading supplier of Overhead Conveyor solutions for the automotive industry

Installations in more than 30 countries



Buffer of bumpers on mezzanine to increase floor space utilization. OCS DC (Digital Control) select bumpers in correct sequence.



Carrier optimized for kitting. Dedicated positions for each part increase visual verification. OCS DC (Digital Control) can support the kitting process with e.g., "Pick-to-light" system.



Instrument panel buffering

OCS 150 manual system that manages instrument panels hanging from injection molding to paint. The product carrier is designed to handle a variety of variants. The carriers are transported through the process as a single piece or in a row.



Contact our Sales Team for a custom-made solution

**GLOBAL
SALES**

Borås - Sweden
www.ocs.se
info@ocs.se

**SCANDINAVIA, FRANCE
& BENELUX**

Borås - Sweden
www.ocs.se
info@ocs.se

**UNITED KINGDOM
& IRELAND**

Warwick Warwickshire - UK
www.ocssystem.co.uk
info@ocssystem.co.uk

**GERMANY, AUSTRIA
& SWITZERLAND**

Löhne - Germany
www.ocssysteme.de
info@ocssysteme.de

**CZECH REPUBLIC, SLOVAKIA,
HUNGARY & POLAND**

Prague - Czech Republic
www.ocssystem.cz
info@ocssystem.cz

Part of
Axel Johnson
International