



**Chicago
Pneumatic**



Air receivers

People. Passion. Performance.



Air Receivers

Functionalities

Suitable for any application using compressed air.

- Storage function in order to handle high air consumption.
- Stabilize pressure peaks and provide a stable air flow
- Perform a preliminary separation and removal of condensate.

Moreover, installing an air receiver allows you to **avoid the following risks**:

- Unstable pressure peaks
- Multiple start/stop of the compressor
- More condensate risk.



Main benefits

- ◀ **Pressure stabilization**
beneficial for the pneumatic tools using the compressed air
- ◀ **Storage**
for handling high air consumption
- ◀ **Pulsation reduction**
Velocity reduction
Temperature reduction
- ◀ **Improvement**
of the life, reliability and functionality of your compressor
- ◀ **Condensate separation**

Types

Painted vessels

Painted vessels are used in the majority of the cases, where the air receiver is not submitted to extreme weather conditions and perfectly clean air is not an absolute prerequisite. The paint job ensures protection against corrosion.

Galvanized vessels

Galvanization is used to protect steel against corrosion. The process itself is simple: the vessel is completely submerged in a zinc liquid bath. As a result, the zinc coating perfectly adheres to the entire surface of the tank, ensuring full protection of the steel.

Vitrified vessels (vitroflex)

These vessels are treated with vitreous enamel, making them water and steam resistant. The complete reliability of this type of treatment is the result of the inorganic composition and the link created between the enamel and metal surface. After having been baked at 850°C, the enamel no longer absorbs water and fully protects the vessel against corrosion.



Air receiver capacity

How to select the size of my receiver?

There is no one rule that fits all as some applications require larger air tanks because of the process.

However, **two rules of thumb** that can help to finetune:

- Your air receiver capacity should be at least 1/4 of your free air delivery expressed in m³/min.
- Base yourself on the compressor's motor power and calculate the capacity:

Motorpower in HP x 30

Example: If you install a 10HP screw compressor, your receiver capacity should be minimally 300 liter.

Connection kit



Correctly sizing your air receiver brings following benefits for your compressors' operations:

- Less waste during unloading period
- Overall smoother operation
- Avoid mechanical stress on several components

Painted standard vessels

Capacity (L)	100	200	270	500	720	900	1000	1500	2000	3000	4000	5000
Pressure (bar)	11	11	11	11	10,8	11	12	11,5	11,5	11,5	11,5	11,5
Diameter Ø	370	446	500	600	750	800	800	1000	1000	1200	1450	1450
H tot (mm)	1172	1570	1668	2055	2030	2120	2315	2305	2805	2965	3070	3570
h (mm)	124	174	170	155	150	130	115	180	180	185	180	180
a	3/4"	1"	1"	1"	1"	1"1/2	2"	2"	2"	3"	3"	3"
b	3/4"	1"	1"	1"	1"	1"1/2	2"	2"	2"	3"	3"	3"
c	3/8"	3/8"	3/8"	3/8"	3/8"	3/8"	3/8"	3/4"	3/4"	3/4"	3/4"	3/4"
d	3/8"	3/8"	N.A.	N.A.	3/8"	3/8"	3/8"	3/8"	3/8"	3/8"	3/8"	3/8"
e	1/2"	1/2"	1/2"	2"	2"	2"	2"	1"1/4	1"1/4	1"1/4	1"1/4	1"1/4
f	1/2"	1/2"	1/2"	2"	2"	2"	2"	1"1/4	1"1/4	1"1/4	1"1/4	1"1/4
l (mm)	298	397	599	775	895	860	745	590	595	700	780	780
m (mm)	998	1222	1304	1560	1705	1780	1685	1860	2355	2410	2430	2930
Kit type included	1	2	3	4	4	6	7	B	B	B	not included	
Weight (kg)	37	51	62	127	180	200	204	278	352	537	802	923
Norm & standards	2014/29/UE						2014/68/EU (PED)					

Zinc standard vessels

Capacity (L)	100	200	270	500	720	900	1000	1500	2000	3000	4000	5000
Pressure (bar)	11	11	11	11	10,8	11	11,5	11,5	11,5	11,5	11,5	11,5
Diameter Ø	370	430	500	600	790	790	790	1000	1000	1200	1450	1450
H tot (mm)	1229	1530	1685	2077	1863	2213	2345	2305	2805	2965	3070	3570
h (mm)	176	135	192	174	200	200	200	180	180	185	180	180
a	3/4"	3/4"	3/4"	1"1/2	1"1/2	2"	2"	2"	2"	3"	3"	3"
b	3/4"	3/4"	3/4"	1"1/2	1"1/2	2"	2"	2"	2"	3"	3"	3"
c	3/8"	3/4"	3/4"	3/4"	3/4"	3/4"	3/4"	3/4"	3/4"	3/4"	3/4"	3/4"
d	3/8"	3/8"	3/8"	3/8"	3/8"	3/8"	3/8"	3/8"	3/8"	3/8"	3/8"	3/8"
e	2"	2"	2"	1"1/4	1"1/4	1"1/4	1"1/4	1"1/4	1"1/4	1"1/4	1"1/4	1"1/4
f	2"	2"	2"	1"1/4	1"1/4	1"1/4	1"1/4	1"1/4	1"1/4	1"1/4	1"1/4	1"1/4
l (mm)	447	397	442	689	690	800	725	590	595	700	780	780
m (mm)	1055	1280	1422	1689	1440	1800	1725	1860	2355	2410	2430	2930
Kit type included	1	A	A	A	A	A	B	B	B	B	not included	
Weight (kg)	40	55	66	143	184	209	224	306	387	591	882	1025
Norm & standards	2014/29/UE						2014/68/EU (PED)					

Vitroflex standard vessels

Capacity (L)	100	200	270	500	720	900	1000	1500	2000	3000	4000	5000	
Pressure (bar)	N.A.	11	11	11	10,8	11	11,5	11,5	11,5	11,5	11,5	11,5	
Diameter Ø	N.A.	430	500	600	790	790	790	1000	1000	1200	1450	1450	
H tot (mm)	N.A.	1530	1685	2077	1863	2213	2345	2305	2805	2965	3070	3570	
h (mm)	N.A.	135	192	174	200	200	200	180	180	185	180	180	
a	N.A.	3/4"	3/4"	1"1/2	1"1/2	2"	2"	2"	2"	3"	3"	3"	
b	N.A.	3/4"	3/4"	1"1/2	1"1/2	2"	2"	2"	2"	3"	3"	3"	
c	N.A.	3/4"	3/4"	3/4"	3/4"	3/4"	3/4"	3/4"	3/4"	3/4"	3/4"	3/4"	
d	N.A.	3/8"	3/8"	3/8"	3/8"	3/8"	3/8"	3/8"	3/8"	3/8"	3/8"	3/8"	
e	N.A.	2"	2"	1"1/4	1"1/4	1"1/4	1"1/4	1"1/4	1"1/4	1"1/4	1"1/4	1"1/4	
f	N.A.	2"	2"	1"1/4	1"1/4	1"1/4	1"1/4	1"1/4	1"1/4	1"1/4	1"1/4	1"1/4	
l (mm)	N.A.	397	442	689	690	800	725	590	595	700	780	780	
m (mm)	N.A.	1280	1422	1689	1440	1800	1725	1860	2355	2410	2430	2930	
Kit type included	N.A.	A	A	A	A	A	B	B	B	B	not included		
Weight (kg)	N.A.	50	60	130	167	190	204	278	352	537	802	932	
Norm & standards	N.A.	2014/29/UE						2014/68/EU (PED)					

Painted high pressure vessels

Capacity (L)	500	1000	2000	3000	4000	5000
Pressure (bar)	16	16	16	16	16	16
Diameter Ø	600	800	1000	1200	1430	1430
H tot (mm)	2055	2315	2810	2930	3110	3610
h (mm)	155	115	175	170	190	190
a	1"	2"	2"	2"	2"	2"
b	1"	2"	2"	2"	2"	2"
c	3/8"	3/8"	3/4"	3/4"	3/4"	3/4"
d	N.A.	3/8"	3/8"	3/8"	3/8"	3/8"
e	2"	2"	2"	2"	2"	2"
f	2"	2"	2"	2"	2"	2"
l (mm)	775	745	565	645	765	765
m (mm)	1560	1685	2340	2370	2450	2950
Kit type included	5	8	C	C	not included	
Weight (kg)	159	246	490	620	905	1055
Norm & standards	2014/68/EU (PED)					

Zinc high pressure vessels

Capacity (L)	500	1000	2000	3000	4000	5000
Pressure (bar)	16	16	16	16	16	16
Diameter Ø	600	790	1000	1200	1430	1430
H tot (mm)	2120	2365	2810	2930	3110	3610
h (mm)	175	200	175	170	190	190
a	2"	2"	2"	2"	2"	2"
b	2"	2"	2"	2"	2"	2"
c	3/4"	3/4"	3/4"	3/4"	3/4"	3/4"
d	3/8"	3/8"	3/8"	3/8"	3/8"	3/8"
e	2"	2"	2"	2"	2"	2"
f	2"	2"	2"	2"	2"	2"
l (mm)	485	725	565	645	765	765
m (mm)	1745	1725	2340	2370	2450	2950
Kit type included	C	C	C	C	not included	
Weight (kg)	176	308	539	682	995	1160
Norm & standards	2014/68/EU (PED)					

Vitroflex high pressure vessels

Capacity (L)	500	1000	2000	3000	4000	5000
Pressure (bar)	16	16	16	16	16	16
Diameter Ø	600	790	1000	1200	1430	1430
H tot (mm)	2120	2365	2810	2930	3110	3610
h (mm)	175	200	175	170	190	190
a	2"	2"	2"	2"	2"	2"
b	2"	2"	2"	2"	2"	2"
c	3/4"	3/4"	3/4"	3/4"	3/4"	3/4"
d	3/8"	3/8"	3/8"	3/8"	3/8"	3/8"
e	2"	2"	2"	2"	2"	2"
f	2"	2"	2"	2"	2"	2"
l (mm)	485	530	565	645	765	765
m (mm)	1745	1725	2340	2370	2450	2950
Kit type included	C	C	C	C	not included	
Weight (kg)	160	280	490	620	905	1055
Norm & standards	2014/68/EU (PED)					

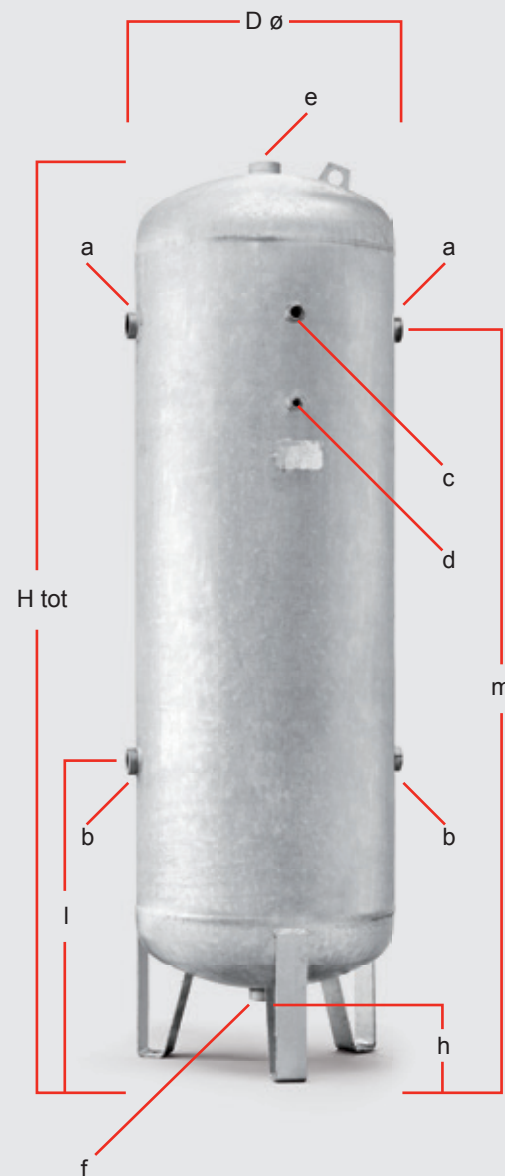

Chicago Pneumatic: full offer, global presence



Piston compressors



Screw compressors



Industrial & vehicle service tools



Portable compressors & generators



Construction equipment



Care. Trust. Efficiency.

Care.

Care is what service is all about: professional service by knowledgeable people, using high-quality original parts.

Trust.

Trust is earned by delivering on our promises of reliable, uninterrupted performance and long equipment lifetime.

Efficiency.

Equipment efficiency is ensured by regular maintenance. Efficiency of the service organization is how Original Parts and Service make the difference.

DISTRIBUTED BY

6999610352

www.cp.com