

SPITZE

THREE FLAP CARTON CLOSER C103

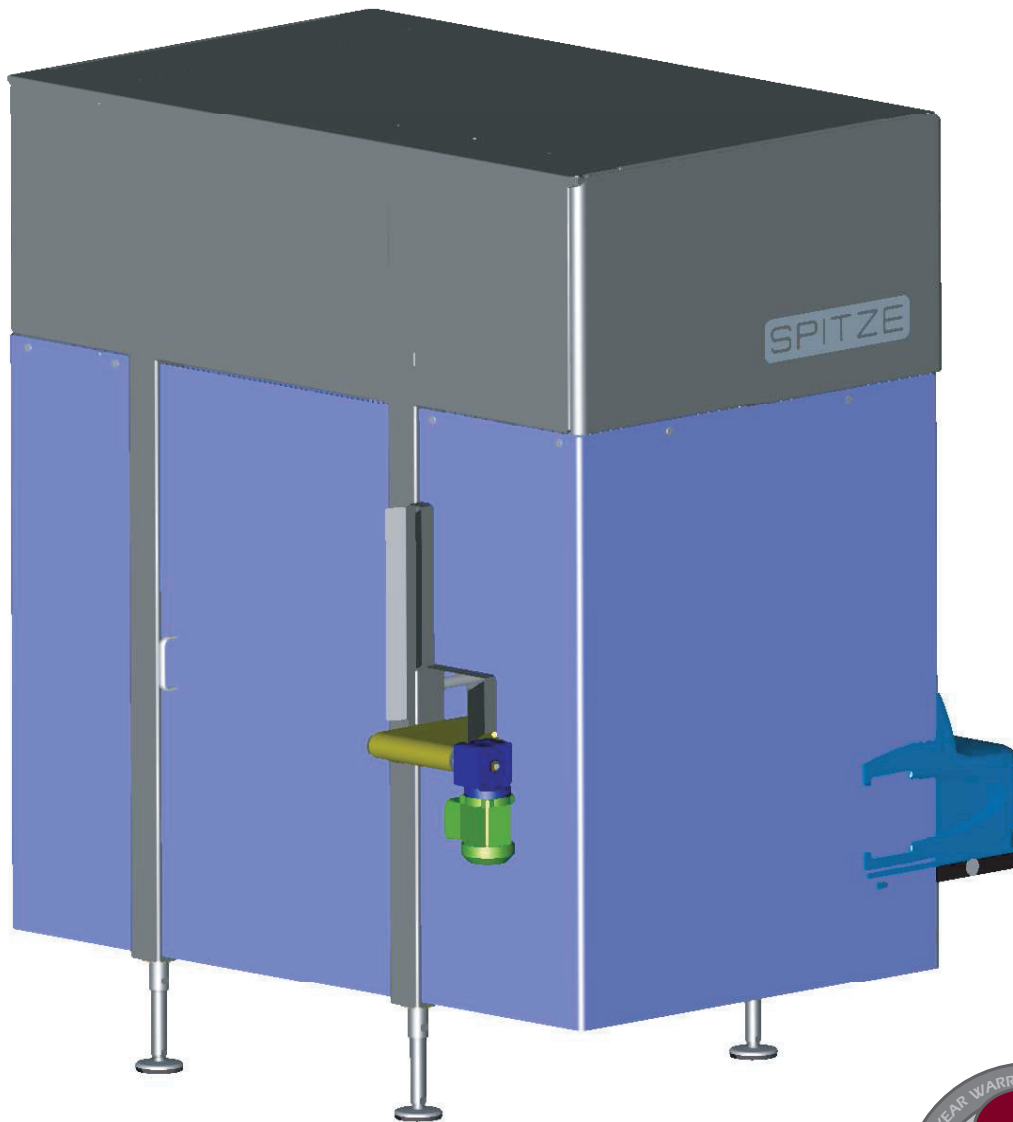

Technical specifications



THREE FLAP CARTON CLOSER C103

Carton size: L 120 - 300 mm
W 80 - 250 mm
H 30 - 120 mm

Speed: up to 25 cpm

Infeed height: 800 - 1000 mm

Outfeed height: 800 - 1000 mm

Weight: 700 kg

Electric: 400V, 50Hz 3-phase, N+PE

Air 0,6 Mpa

Standard features:

- 2 year warranty
- Stainless steel design
- Hygienic design
- Quick and accurate size change
- Position indicators for all mechanical adjustments
- Easy access for service
- No lubrication needed
- Beacon
- Nordson hot melt system
- Inline filters for hot melt

- Anti stick pressure wheels
- Low level glue alarm
- Set back for glue
- Timer for glue
- Counter
- Internet connection
- Left or right hand execution available
- Queue control

Optional features:

- Fully automatic size change
- Flex belt
- Colour touch screen

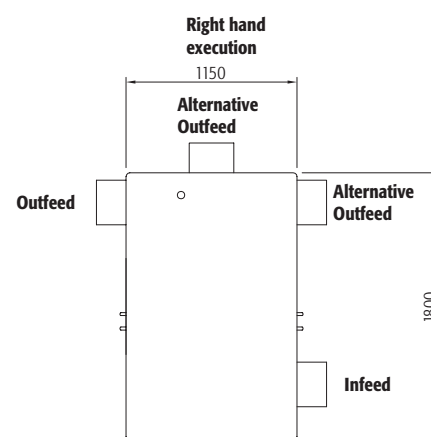
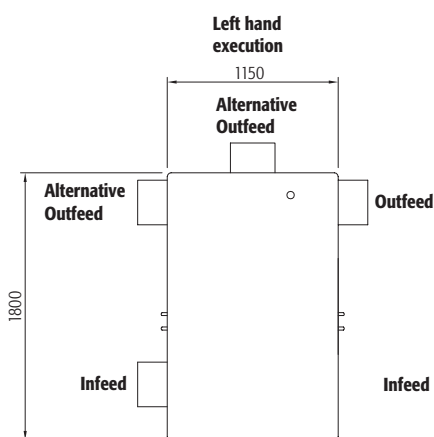
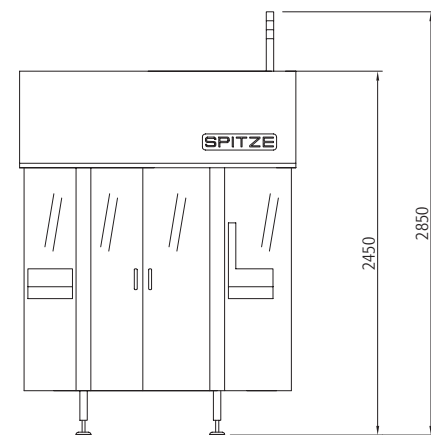
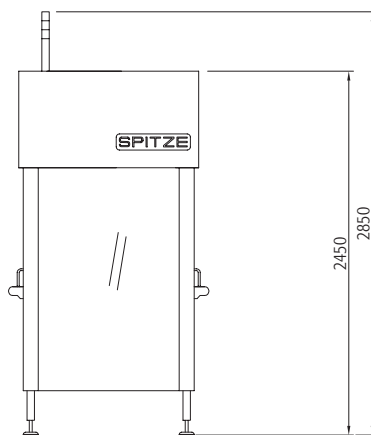

PAT Pending

SPITZE

Spitze AB
Kövlingevägen 1
S-312 50 VALLBERGA
Sweden

Phone +46 430 237 60
Fax +46 430 237 69
info@spitze.se
www.spitze.com